

# SEASTRONG® SILVER BULLET

## ULTIMATE SEALLESS MARINE PUMP

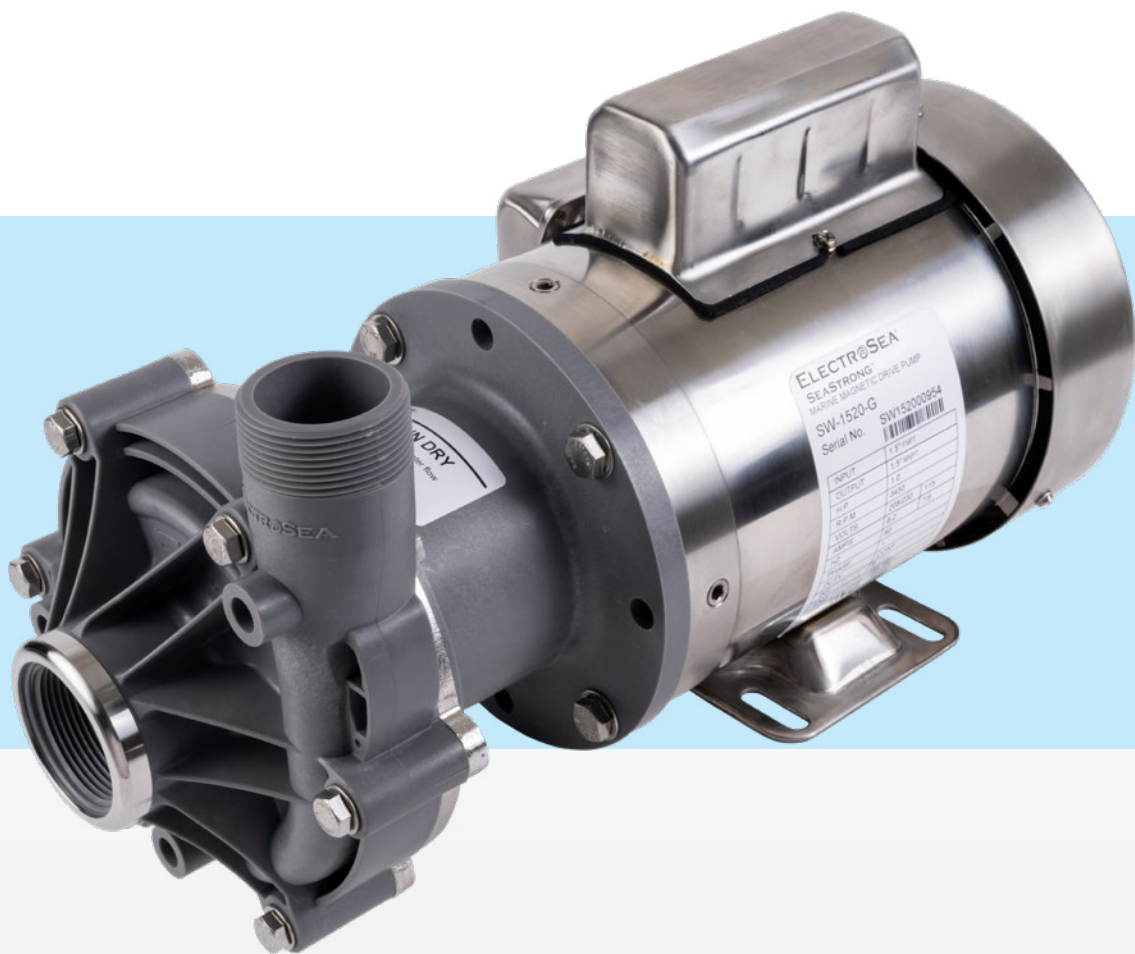

**INSTALLATION AND OPERATION MANUAL**

# TABLE OF CONTENTS

## INTRODUCTION

Table of Contents	2
ElectroSea	3
SeaStrong Silver Bullet	3
Safety Precautions	3-6
Key Components	7
Unpacking & Inspection	7

## INSTALLATION

Mounting	8-9
Plumbing	10-11
Drain Plug (Optional)	11
Electrical Connection	12

## OPERATION

Pump Operation	13
----------------	----

## MAINTENANCE

Pump Disassembly & Inspection	14-17
Replacement Parts	18
Pump Reassembly	19-21

## REPLACEMENT KITS

Wear Kit	22-24
Impeller Kit	25
Wet End Kit	26-27
Motor Kit	28

## DIAGRAMS AND PART LIST

Pump Diagrams	29-30
Part List	31

### WARRANTY POLICY

Please visit our website to view our full warranty terms and conditions: [www.electrosea.com/warranty](http://www.electrosea.com/warranty)

Please read these instructions carefully and follow all instructions, guidelines, and warnings stated in this product manual to guarantee the correct installation, usage, and maintenance at all times. Keep instructions with product for future reference.

By using the product, you hereby affirm that you have thoroughly read and understood all instructions, guidelines, and warnings contained herein. You acknowledge and consent to comply with the terms and conditions set forth in this document. It is understood that the product shall be used solely for its intended purpose and application, adhering to the instructions, guidelines, and warnings as specified in this product manual and in accordance with all relevant laws and regulations.

Failure to read and adhere to the provided instructions and warnings may lead to potential injuries to yourself and others, damage to the product, or harm to surrounding property. Please be aware that this product manual, including its instructions, guidelines, and warnings, may be subject to modifications and updates. To access the most current product information, visit [www.electrosea.com](http://www.electrosea.com).

COPYRIGHT © 2023 No part of this publication may be reproduced, translated, stored in a retrieval system, or transmitted in any form or by any means electronic, mechanical, photocopying, recording or otherwise without prior written consent by ElectroSea, LLC. Every precaution has been taken in the preparation of this manual to ensure its accuracy. ElectroSea assumes no responsibility for errors or omission. Neither is any liability assumed for damages resulting from the use of this product and information contained herein.

# ELECTROSEA®

ElectroSea was created when the owners of a sportfishing vessel invented “a better way” to prevent biofouling in their seawater cooling system. Solving complex technical problems is our expertise. Our executive management team has been developing innovative solutions for more than 50 years. With an expert team of “old salts” who eat, sleep, and breathe boating, ElectroSea will improve your time on the water.

# SEASTRONG® SILVER BULLET

ElectroSea’s advanced sealless magnetic-drive centrifugal marine pump delivers bulletproof reliability for your marine air conditioning, chiller, and livewell systems. Unlike traditional direct-drive pumps that leak at the shaft seals, the SeaStrong Silver Bullet pump has no shaft seal and instead uses a magnetic close-coupled design. SeaStrong Silver Bullet is based on millions of actual run hours in the toughest conditions aboard marine vessels. ElectroSea’s patent-pending pump design features have been engineered into SeaStrong Silver Bullet to provide superior performance and reliability you can trust. SeaStrong is an evolution in marine pump engineering for chilled water or seawater applications.

# SAFETY PRECAUTIONS

**! WARNING: READ THIS MANUAL COMPLETELY BEFORE INSTALLING AND OPERATING THIS UNIT. FAILURE TO FOLLOW THESE PRECAUTIONS CAN RESULT IN SERIOUS INJURY OR DEATH.**

The following safety alert symbols are used to alert you to potential physical injury hazards. Obey all safety messages that follow these symbols to avoid possible injury or death.

**! DANGER!** This symbol indicates a hazardous situation that, if not avoided, will result in death or serious injury.

**! WARNING:** This symbol indicates a hazardous situation that, if not avoided, could result in death or serious injury.

**! CAUTION:** This symbol indicates a hazardous situation that, if not avoided, could result in minor or moderate injury.

**i NOTICE:** This symbol is used to address practices not related to physical injury and indicates additional information that is not related to physical injury.

## SAFETY PRECAUTIONS

### SUPPLEMENTAL DIRECTIVES

To reduce the risk of accidents and injuries, please observe the following directives before proceeding to install or operate this product. The installation must comply with all applicable local or national codes, including the latest edition of the following standards:

U.S.A.

- ANSI/NFPA70, National Electrical Code (NEC)
- American Boat and Yacht Council (ABYC)

Canada

- CSA C22.1, Parts I & II, Canadian Electrical Code

### GENERAL SAFETY CONSIDERATIONS

 **WARNING: MAGNETIC HAZARD. Failure to obey the following warnings could result in death or serious injury:**

- This pump contains powerful magnets. Exposed magnets (pump not connected to motor) produce powerful magnetic fields. Individuals with cardiac pacemakers, implanted defibrillators, other electronic medical devices, metallic prosthetic heart valves, internal wound clips (from surgery), metallic prosthetic devices, or sickle cell anemia must not handle or be in the proximity of the magnets contained inside the pump. If any of these conditions apply to you, then consult a health care provider for specific recommendations before working with this pump.
- This pump should only be disassembled and assembled using the recommended procedures. The magnetic attraction is powerful enough to rapidly pull the motor end and the wet end together. Do not place fingers between the mating surfaces of the motor and wet ends to avoid injuries. Keep the drive magnet and impeller assembly away from metal chips, metal particles, or items with magnetic stripes, such as credit cards and magnetic computer media.

 **WARNING: ELECTRICAL SHOCK, FIRE, AND/OR EXPLOSION, AND MECHANICAL HAZARD. Failure to obey the following warnings could result in death or serious injury:**

- Do not operate the pump in a highly explosive environment unless the pump has a label to indicate it is rated for ignition protection.
- Not intended for hazardous areas with flammable gases or combustible materials.
- Do not pump flammable or combustible liquids.
- The pump is NOT submersible. Do NOT submerge the pump or operate in standing water.

## SAFETY PRECAUTIONS

- Before attempting to make any electrical connections, ensure the electrical power is off and the water valves are completely closed.
- Secure and seal all wire connections to protect from arcing.
- Do not modify this product in any way. Modification can be extremely hazardous.
- Read all pump labels and ensure the power supply meets the requirements and labeled specifications.

 **WARNING: FLOOD/LEAK HAZARD. Failure to obey the following warnings could result in death or serious injury:**

- Never run the pump at less than minimum flow or with the discharge valve closed.
- Do not start or operate the pump with the suction valve closed.
- Do not continue to operate the pumping system when a known leak exists.
- Do not perform service or maintenance when the pumping system is pressurized.
- Do not use PTFE on plastic connections.
- For Marine Vessels:
  - Use marine-grade hose and double clamp with two stainless-steel clamps, reversing the clamps. Failure to properly secure seawater connections could result in sinking the vessel.
  - All seawater plumbing connections must be performed by a qualified marine installation professional.
  - When mounting in the bilge, do not drill through the hull of the boat.
  - Avoid over-tightening parts as they may crack and result in sinking the vessel.

 **WARNING: BURN HAZARD. Failure to obey the following warnings could result in death or serious injury:**

- The motor is designed to run at temperatures up to 240 °F (115 °C) external. Do not touch during operation.

 **WARNING: CHEMICAL HAZARD. Failure to obey the following warnings could result in death or serious injury:**

- Always wear protective clothing and eye protection when handling chemicals that may be used to operate or maintain the pump.
- Follow standard safety procedures when handling corrosive or personally harmful materials that may be used with the pump.

## SAFETY PRECAUTIONS

- Follow proper procedures for draining and decontaminating the pump before performing maintenance on it.

**⚠ WARNING: OTHER HAZARDS.** Failure to obey the following warnings could result in death or serious injury:

- This pump has components that rotate while in operation. Always lockout the motor before servicing. Always disconnect the pump, including all connected equipment, from the power source before servicing.
- The pump and associated components are heavy. Failure to properly support the pump during lifting and movement could result in serious injury or damage to the pump and components.

## INSTALLATION AND OPERATION PRECAUTIONS

**i NOTICE:**

- This pump should never be operated without liquid in the casing or at less than minimum flow. This can create a RUN-DRY CONDITION THAT MAY DAMAGE THE PUMP.
- Never start or operate with a closed suction valve and/or a closed discharge valve.
- Do not continue to operate the pump when unusual noise or vibration occurs.
- Always provide adequate NPSHa (net positive suction head available). It is recommended to provide at least 2 feet (61 cm) above the NPSHr (net positive suction head required).
- If the pump is used on variable speed drive, do not exceed the frequency for which the pump was designed (for example, if the pump is a 60 Hz model, do not exceed 60 Hz).
- DO NOT decrease seawater flow below the manufacturer's specifications for downstream cooling equipment.
- Limit the use of 90° elbows as they restrict flow and cause pressure drop.
- Use only original parts supplied by ElectroSea. They are made of special high-quality composites and other materials.

## KEY COMPONENTS

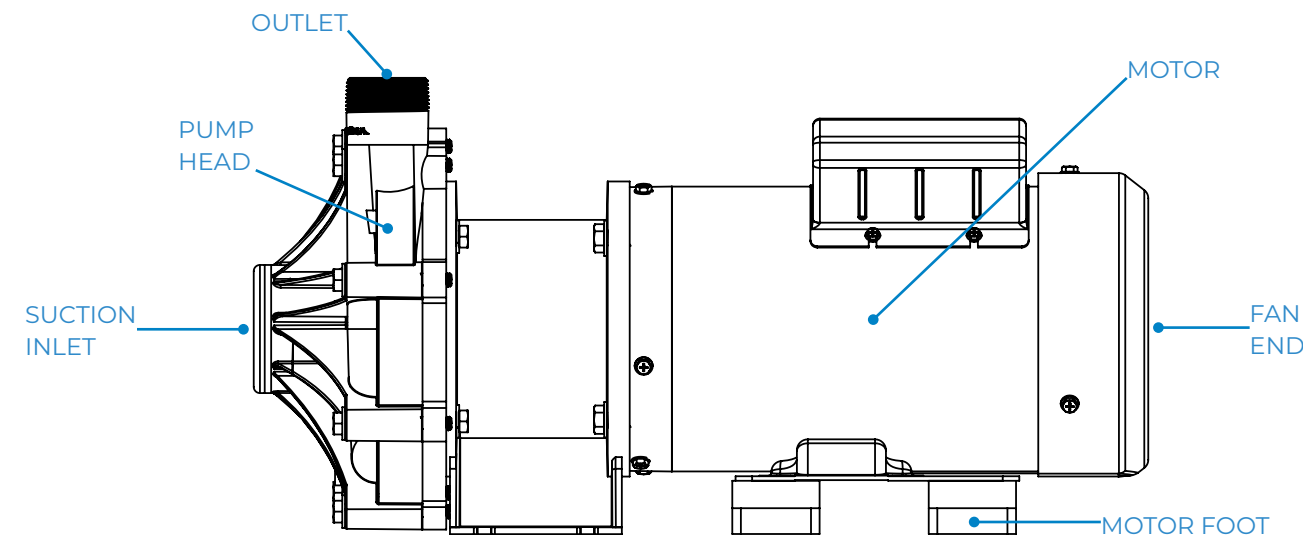

## UNPACKING & INSPECTION

Unpack the pump and examine it for any signs of shipping damage. If any damage is detected, save the packaging and notify the carrier immediately.

## MOUNTING

**i** **NOTICE:** Failure to obey the following instructions could result in damage to the pump or components and cause property damage.

### MOUNTING CONSIDERATIONS

The pump head and motor feet must be securely fastened to a solid foundation. The pump is intended for horizontal mounting with the feet on the bottom. If other mounting is required, contact ElectroSea.

- **Below Waterline**
  - The pump must be installed below the waterline. Seawater must freely flow into the pump head.
- **Level Horizontal Position**
  - Place the pump in a location that will allow mounting in a level, horizontal position on a secure foundation.
- **Motor Foot Spacer**
  - If the pump has a pump-head foot, motor-foot spacer(s) (included) must be used to securely support the motor. Both the motor foot and the pump-head foot must be securely fastened to a solid foundation.
- **Mounting Hardware Mounting**
  - Mounting hardware is not included. The bolts used to secure the pump to the packaging should not be used for mounting the pump.
- **Ventilation**
  - The installation location must allow for air flow around the pump for proper operation and cooling of the motor.

### ROTATING THE PUMP HEAD (OPTIONAL)

The pump is preconfigured with a vertical discharge orientation, which is applicable to most installations. When preparing the pump installation, it may be necessary to rotate the pump head to improve the ease of installing the pump and associated piping. Rotating the pump head is optional and should be done before mounting the pump. Make sure the O-ring is properly seated in the groove after rotating. The pump face can be set to a horizontal configuration by rotating it 90 degrees from the vertical configuration. When the pump discharge is in a horizontal configuration, the motor must be shimmed to raise the front of the pump to avoid interference.

## MOUNTING

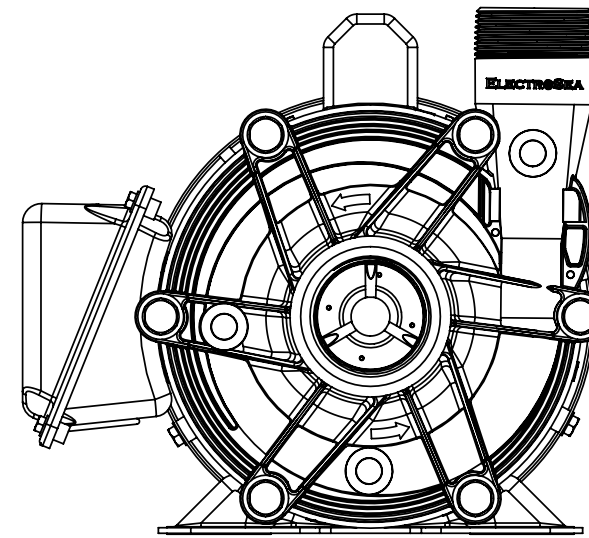

**VERTICAL DISCHARGE**

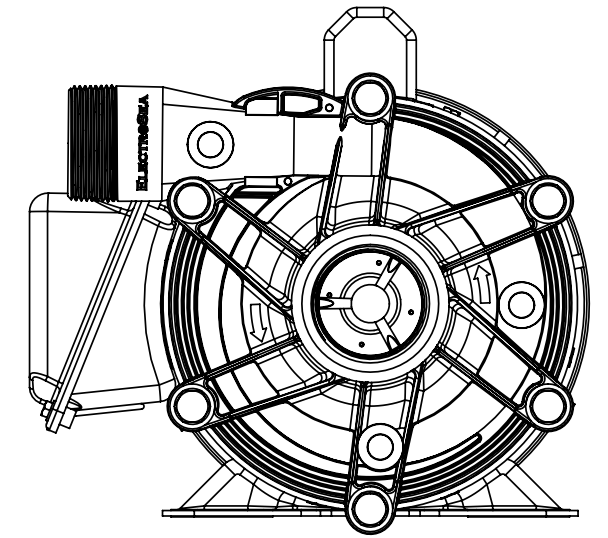

**HORIZONTAL DISCHARGE**

### MOUNTING THE PUMP

- Place the pump motor in the desired location and mark the position of the mounting holes.
- Drill holes for the mounting screws.
- Make sure that holes are NOT being drilled into the hull of the boat as this could sink the vessel.
- If the pump was packaged with plastic motor mounts, make sure the mounts remain under the motor during installation.

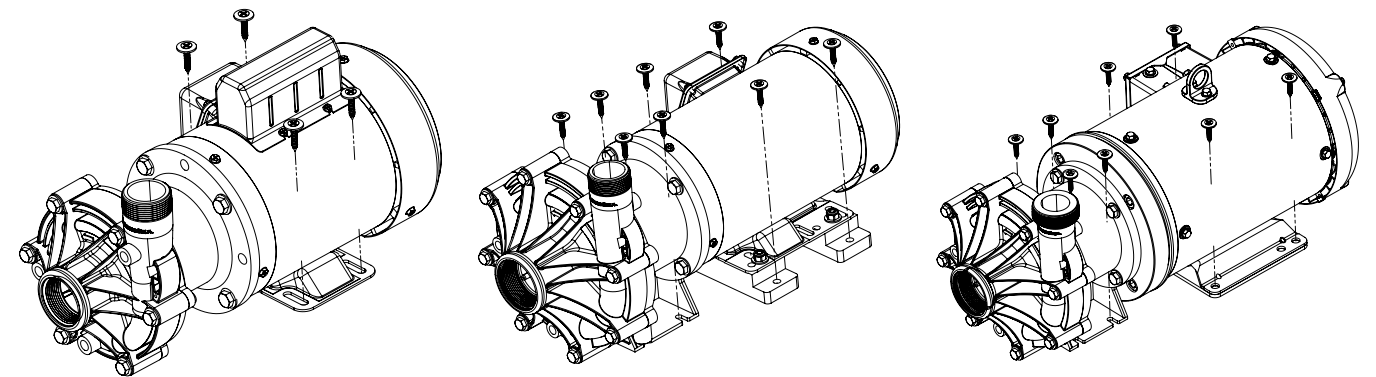

## PLUMBING

Follow all national and local plumbing standards and codes for marine vessel plumbing. Ensure seacocks are closed before removing, changing, or fixing any plumbing. Plumbing should be performed by a qualified technician.

**⚠ WARNING: Failure to close all seacock valves can result in sinking the vessel and severe injury.**

**⚠ WARNING: DO NOT overtighten fittings to the pump. Connections should be hand tightened as much as possible and then tightened about a 1/2 turn with a wrench. Extreme care should be taken if using metal fittings as they can be overtightened and crack the pump head.**

**⚠ WARNING: DO NOT use PTFE-based tape or sealants because they lead to overtightening. Use a non-PTFE plastics-compatible thread sealant, such as Spears Blue 75 thread sealant.**

**i NOTICE: Metal fittings can damage the pump head; care must be taken if threading metal fittings into the pump.**

**i NOTICE: Installer must verify flow rate meets consumer requirements (air conditioning, refrigeration, hydraulics, etc.) after pump installation. Damage may occur if the supplied flow rate is greater or less than the specified flow-rate requirements of the consumers that use this water for cooling.**

- **Unrestricted Suction**

- It is important to provide unrestricted flow to the pump on the suction side.
- Strainers and pipe/hose diameter should be the same size or larger than the input size of the pump.
- Avoid right-angle fittings when possible. Suction-line plumbing should be as straight as possible.
- Keep bends, valves, strainers, and other fittings away from the suction inlet at a distance of at least 10 times the diameter of the suction inlet.
- Suction line distance from the thru-hull to the pump should be as short as possible.
- The suction line should be at least as large as the suction inlet port or one pipe size larger so that it does not affect the NPSHa (net positive suction head available). Do not reduce the suction line size.

- **Debris and Filtration**

- A strainer on the inlet pipe should be used to remove debris before the liquid or seawater enters the pump.

- **Support Weight of Plumbing**

- Input and output plumbing should be supported near the pump head to eliminate stress on the pump.

## PLUMBING

- **Flooded Suction**

- The pump head must be below the waterline. Final plumbing must fill the pump head with water via gravity. To avoid air pockets, the suction line should not have any high spots. The suction hose/piping should be as level as possible or angled slightly upwards toward the pump.

- **NPT Threaded Connections**

- DO NOT overtighten fittings to the pump head. Connections should be hand tightened as much as possible and then tightened about a 1/2 turn with a wrench. Extreme care should be taken if using metal fittings as they can be overtightened and crack the pump head.

- **Valves**

- Isolation valves on the suction and discharge lines can be used to make the pump accessible for maintenance.
- A check valve and control valve (if used) may be installed on the discharge line. The check valve helps prevent the pump from water hammer damage. This is particularly important when the static discharge head is high. The control valve is used for regulating flow. Do NOT deadhead the pump or close off the control valve entirely when the pump is running.

## DRAIN PLUG (OPTIONAL)

A drain plug can be installed in the impeller housing to provide the ability to connect a drain line. The following instructions explain how to connect an optional drain plug on SeaStrong models.

1. Clamp the pump face to a stable surface.
2. Using a 7/16-inch drill and drill completely through the molded boss into the interior of the pump face, using the molded boss as a guide.
3. Using a 1/4-inch NPT tap and tap the hole in the molded boss to the appropriate depth. Do not tap too deep or the pump face may be damaged.
4. Install the drain plug, being careful not to overtighten.

## ELECTRICAL CONNECTION

 **WARNING:** Always disconnect all electrical connections to the pump before beginning any work on it.

 **NOTICE:** Refer to the wiring diagram affixed to the pump.

To ensure the safety of the installer and the vessel, it is important to disconnect power from all systems and supply lines before working on electrical connections. Electrical work should be performed by a qualified technician.

- Prior to connecting to power, check the nameplate specifications and ensure proper grounding.
- Check the pump voltage, frequency, and phase to ensure it matches the installation power source. Verify the supply circuit matches the label voltage, phase, and frequency. DO NOT install the pump if there are any differences.
- The motor must be connected to a circuit-protection device, such as a fuse or circuit breaker of appropriate size per applicable codes. Three-phase motors must have all three phases protected.
- Connect AC lines per the label found inside the electrical junction box or on the side of the motor.
- Some pumps are dual voltage and will need to be wired to the specific voltage for your application.
- Use appropriate electrical-box connections to ensure the electrical junction box is watertight.
- Follow all applicable National Electric Code, NEMA MG-2, IEC, and ABYC standards, requirements, and local electrical codes.

## PUMP OPERATION

 **WARNING:** Never start or run the pump dry. Always prime the pump before starting.

 **WARNING:** If used on a marine vessel, pay careful attention when cleaning the sea strainer to bleed all air from the seawater strainer, seawater pipes, and pump head.

 **WARNING:** Running the pump dry, even a short time, can cause permanent damage and is NOT covered under warranty.

### PRIME THE PUMP

1. Open the inlet (suction) and outlet (discharge) valves completely and ensure the pump, strainer, and pipes fill with water on their own.

 **NOTICE:** DO NOT turn the pump ON until it is completely filled with water. If air is trapped in the top of the strainer, bleed it out before continuing. If air is trapped inside the pump head, it may become airlocked or damage the pump. Carefully bleed air from pump head by slowly releasing air on output with the water supply open.

2. Close the discharge valve.
3. Turn the pump on. Slowly open the discharge valve.
4. Adjust the flow rate and pressure by regulating the discharge valve. Do not attempt to adjust the flow with the suction valve.

### CHECK ROTATION

Three-phase SeaStrong pumps must be checked for correct rotation. Incorrect rotation of the pump impeller greatly reduces the flow and pressure. Single-phase SeaStrong pumps are prewired at the factory for correct rotation.

#### To verify correct rotation on three-phase pumps:

1. Check plumbing and electrical connections.
2. Open all supply and discharge valves and ensure seawater flows into the pump head freely.
3. Run the pump for a couple of seconds while observing the motor fan. When looking at the pump from the fan end, the fan should rotate clockwise (the same way shown on the arrow in the pump head).

**If the rotation is incorrect,** interchange any two (2) of the three (3) AC lines with each other to change the rotation. Only swap two (2) lines; one (1) line must stay unchanged. Retest rotation by repeating steps 1-3.

## PUMP DISASSEMBLY & INSPECTION

SeaStrong pumps should be kept clean and monitored to ensure proper operation. Do not operate the pump if there are leaks or damage to the pump.

- Clean the pump with a damp rag. The pump is washdown rated and can be sprayed with low-pressure fresh water if needed.
- If storing in a cold climate, drain all water from the pump to prevent damage from freezing. DO NOT spray with high-pressure liquids.
- For best results, the pump should be examined on an annual basis and after the first six months of operation.

The SeaStrong pump should only be disassembled for scheduled maintenance inspection or to resolve issues. The following instructions are used for removing the wet end of the pump and disassembling it to inspect for wear or damage.

**! WARNING: ROTATING PARTS.** The pump contains moving parts that rotate while it is running. Adhere to the relevant safety regulations and disconnect the motor from the power source when conducting maintenance or servicing.

**! WARNING: MAGNETIC FORCE HAZARD.** Follow only the prescribed procedures when disassembling and reassembling this pump. The magnetic force is sufficiently strong to swiftly draw together the motor end and the wet end. To prevent injuries, refrain from putting your fingers between the connecting surfaces of the motor and wet ends. Keep the drive magnet and impeller assembly clear from any metal chips or particles.

**! WARNING: CHEMICAL HAZARD.** This pump may be used for the transfer of various potentially hazardous chemicals. Always wear protective clothing and eye protection and adhere to established safety protocols when managing corrosive or harmful substances. It is essential to meticulously execute the correct methods for draining and decontaminating the pump before proceeding with its disassembly and inspection. It is possible that trace amounts of chemicals could be present during the inspection process.

**i NOTICE:** Reference pages 29-31, Pump Diagrams and Part List, for component names.

1. Turn OFF power to the pump at the breaker.
2. Close all valves connected to the pump and flush and drain all fluid.

**i NOTICE:** If using hazardous chemicals or fluids at high temperature, decontaminate the pump and allow the pump to reach ambient temperature before proceeding.

## PUMP DISASSEMBLY & INSPECTION

3. Disconnect all hoses and fittings connected to the pump inlet and outlet.
4. If possible, remove the pump from its operating location so it can more easily be worked on. Clamp or secure the motor to a stable surface.
5. Remove the (4) 3/8 x 1" bolts and flat washers securing the pump to the motor.
6. Firmly grab the pump-end assembly and pull straight back to disengage the motor and the pump-end assembly. If the pump cannot easily be removed from its operating location, then firmly hold one side (either the pump-end assembly or the motor) and pull straight out to disengage the pump-end assembly and motor. Make sure to keep track of the O-ring for the motor adapter.

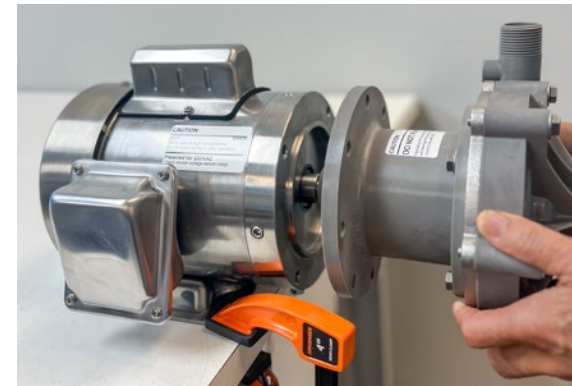

7. Place the pump on a level surface with the pump inlet facing up. Remove all 5/16" pump head bolts and flat washers.

8. Pull the pump face straight up to remove. Inspect the pump face for signs of wear or damage.

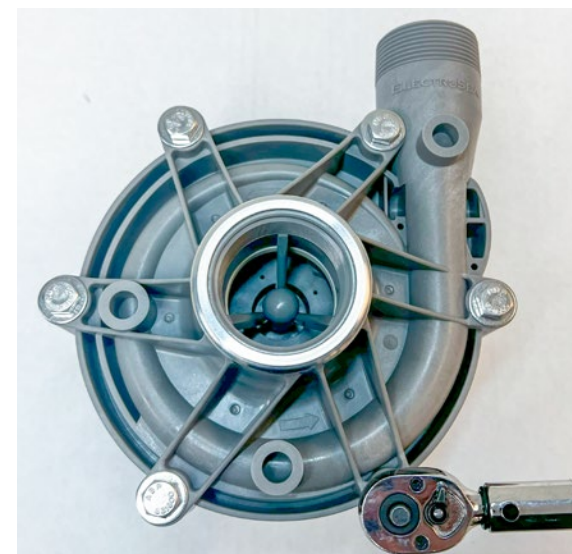



## PUMP DISASSEMBLY & INSPECTION

9. Remove the impeller assembly. Replace any parts that appear worn or damaged.

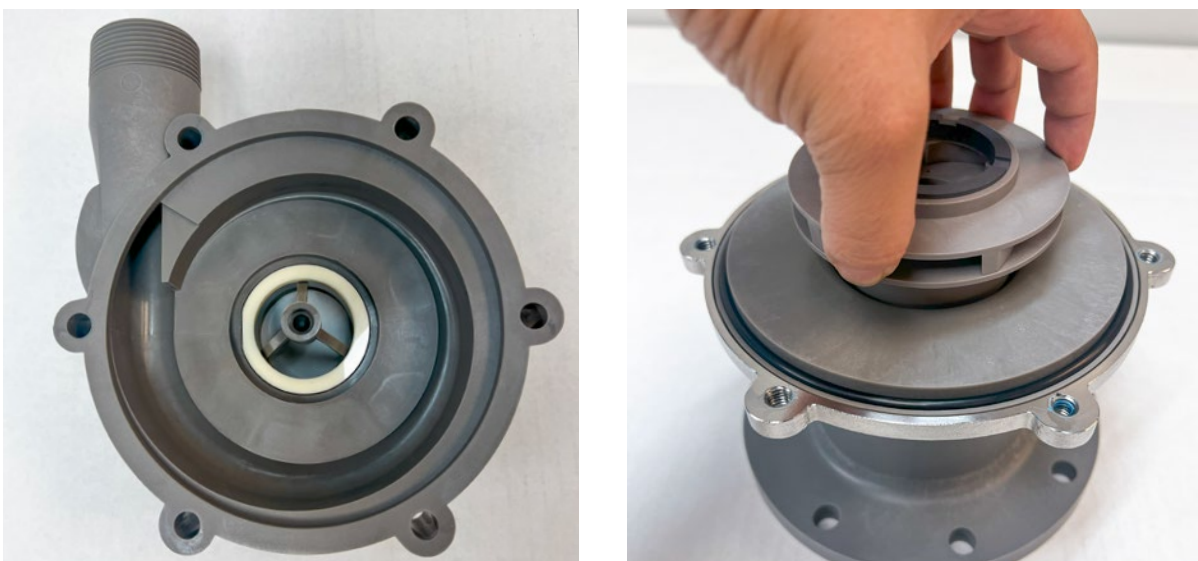

a. **Impeller bushing inspection** – A significantly worn bushing can lead to permanent damage to the pump. The impeller bushing should fit snugly on the impeller shaft. If the impeller assembly wobbles on the shaft, measure the internal diameter of the impeller bushing. If the internal diameter is larger than what is listed in the table below, replace the impeller bushing (included in the Wear Kit).

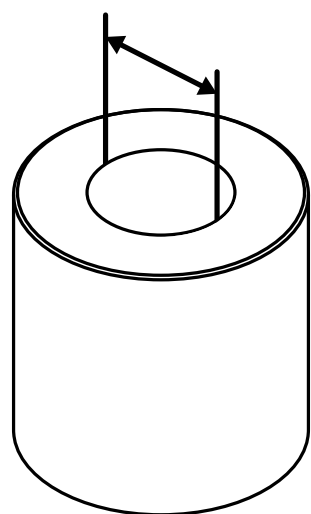

SEASTRONG PUMP MODEL	MAXIMUM IMPELLER BUSHING INNER DIAMETER
<b>SB-030</b>	0.400 in
<b>SB-045</b>	0.400 in
<b>SB-062</b>	0.400 in
<b>SB-075</b>	0.400 in
<b>SB-100</b>	0.400 in
<b>SB-137</b>	0.525 in
<b>SB-150</b>	0.525 in

## PUMP DISASSEMBLY & INSPECTION

b. **Impeller thrust ring inspection** – A significantly worn thrust ring can lead to permanent damage to the pump. The thrust ring should protrude from the composite impeller. Excessive negative suction pressure can cause the thrust ring to contact the pump face and wear. If the wear indicator depth on the thrust ring is less than what is listed in the table to the right, replace the impeller thrust ring (included in the Wear Kit).

SEASTRONG PUMP MODEL	MINIMUM THRUST RING DEPTH
<b>SB-030</b>	0.032 in
<b>SB-045</b>	0.032 in
<b>SB-062</b>	0.032 in
<b>SB-075</b>	0.032 in
<b>SB-100</b>	0.032 in
<b>SB-137</b>	0.030 in
<b>SB-150</b>	0.030 in

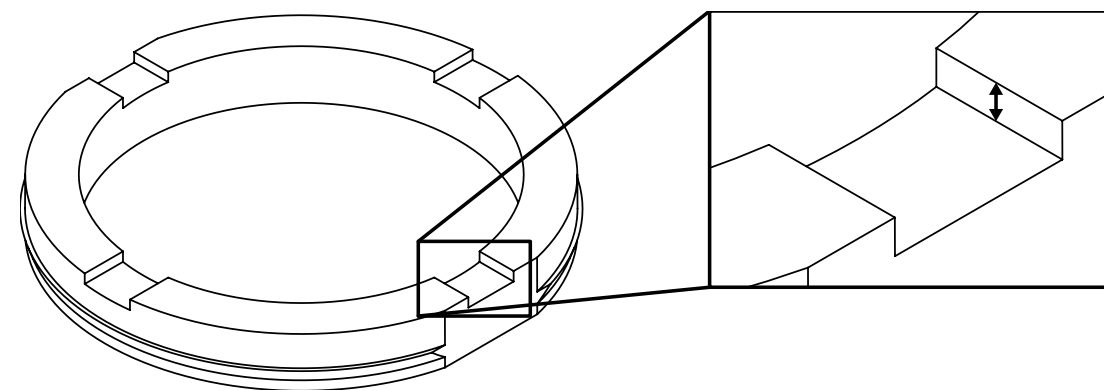

10. Inspect the inside of the barrier for signs of rubbing. Inspect the impeller shaft for signs of cracking, chipping, scoring, or wear. Remove the O-ring from the barrier and inspect for degradation, chemical attack, swelling, brittleness, cuts, etc. If any parts appear worn or damaged, replace parts included in the Wet End Kit.



## REPLACEMENT PARTS

ElectroSea offers multiple SeaStrong Silver Bullet kits for component replacement:

- **Wear Kit** – impeller bushing, impeller thrust ring, and barrier O-ring
- **Impeller Kit** – impeller, impeller thrust ring, impeller magnet, and impeller bushing
- **Wet End Kit** – pump face, pump-face bolts, impeller shaft, impeller, impeller magnet, impeller bushing, impeller thrust ring, barrier O-ring, barrier, base plate, and base-plate O-ring
- **Motor Kit** – motor and magnetic shaft coupler

## PUMP REASSEMBLY

1. Place the motor adapter so the large flange is facing down. Rotate the adapter so the four holes in the smaller flange are in the horizontal position. Install the O-ring in the groove.
2. Install the base plate if it was removed.
3. Install (4) bolts and flat washers. Before installing each bolt, use Loctite 242 or equivalent and tighten evenly using a star pattern. Tighten to 60 in-lb (6.8 N-m).



4. Install the O-ring in the groove of the base plate.
5. Carefully install the impeller assembly by sliding it over the impeller shaft in the barrier.

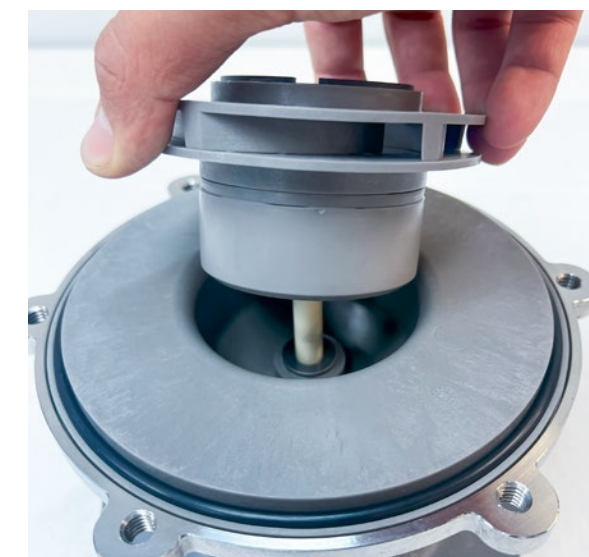

## PUMP REASSEMBLY

6. Install the pump face, making sure the discharge is in the correct orientation. Align the shaft in the barrier with the front shaft support in the pump face. Press the pump face down into position.
7. Install the bolts and flat washers on the pump face. Before installing each bolt, use Loctite 242 or equivalent and tighten all the bolts evenly using a star pattern. Tighten to 60 in-lb (6.8 N-m).

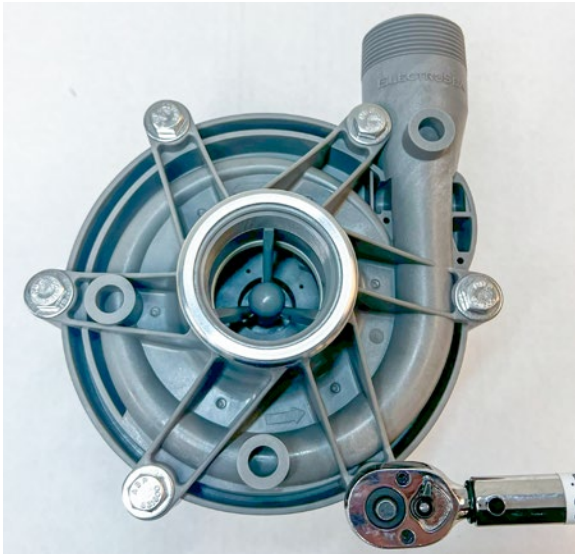

8. Install the O-ring on the motor adapter/pump-end assembly. Silicone grease, such as Super Lube, may be optionally applied to the O-ring.

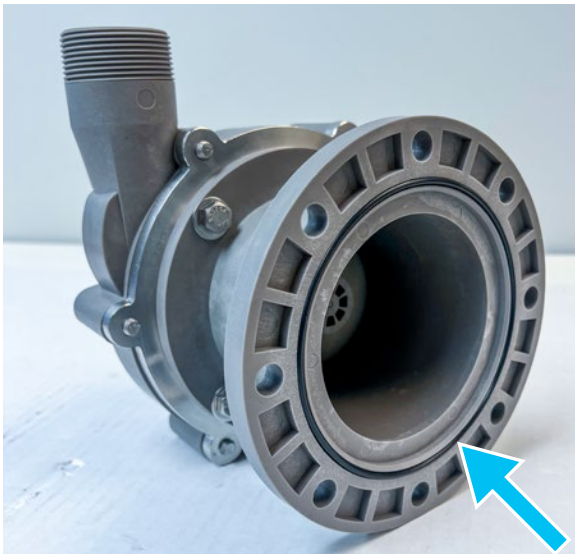

## PUMP REASSEMBLY

9. Align the holes on the pump-end assembly with the holes on the motor adapter.



10. Reinstall the bolts and washers and tighten evenly using a star pattern. Before installing each bolt, use Loctite 242 or equivalent and tighten to 60 in-lb (6.8 N-m).

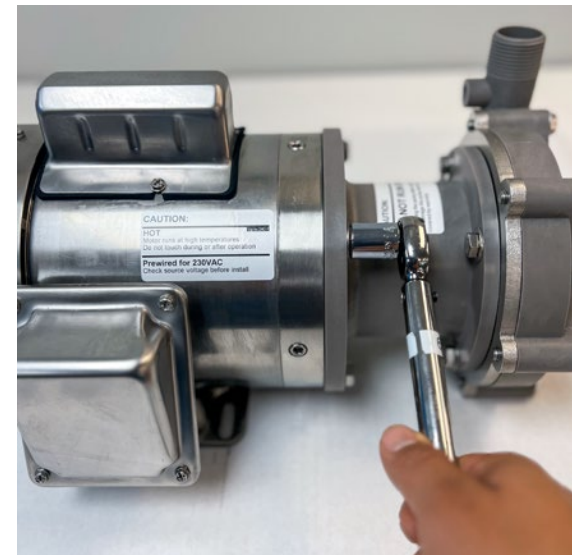

## WEAR KIT

### IMPELLER BUSHING & THRUST RING REPLACEMENT

If the impeller bushing, thrust ring, or barrier O-ring must be replaced, follow the instructions below to install components of the Wear Kit (sold separately).

1. Follow steps 1 – 9 of the pump disassembly and inspection instructions (pages 14 – 17).
2. Separate the impeller from the impeller magnet.

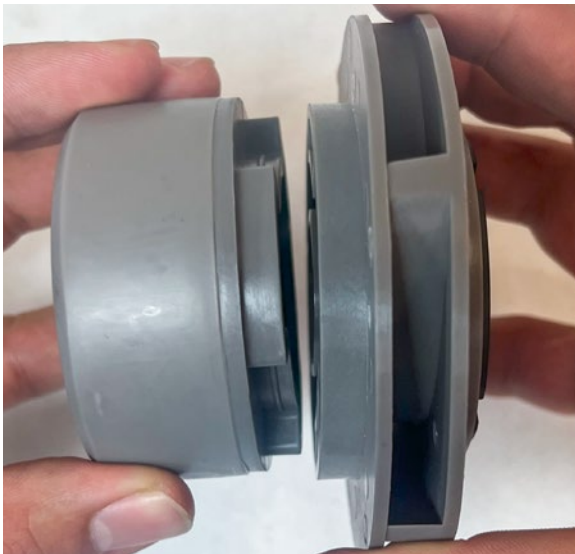

3. Place the impeller magnet in an arbor press with the bottom facing up.

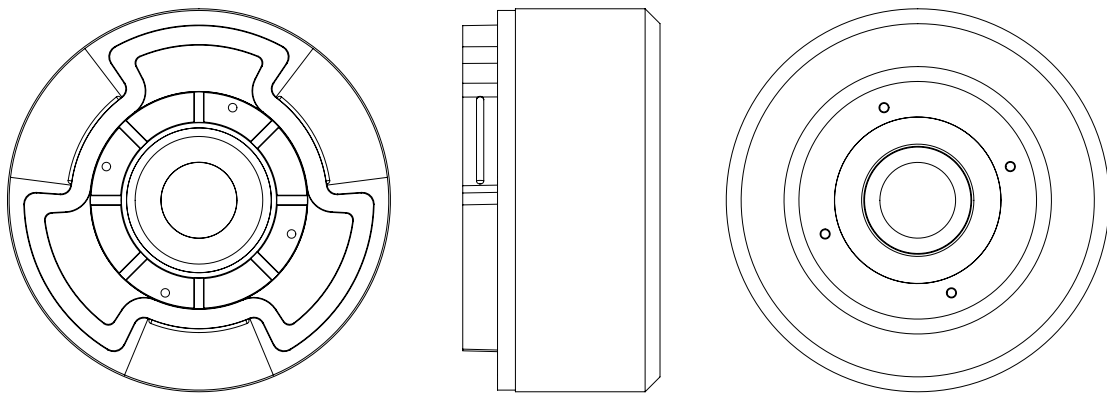

## WEAR KIT

4. Insert the appropriate size socket on the bottom side of the impeller magnet and press the bushing out. If necessary, support the bottom of the impeller magnet with blocks to allow the bushing to fall out.

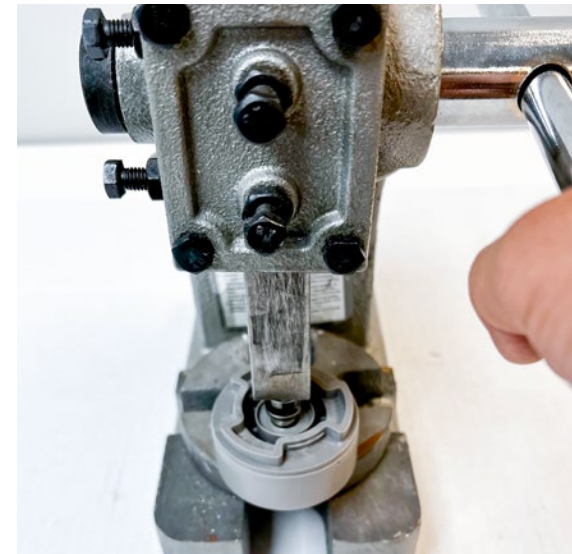

5. Remove impeller magnet from the arbor press.
6. To replace the bushing, place the top of the impeller magnet on an arbor press.
7. Insert the bushing into the center of the impeller magnet.
8. Press the bushing into place until it is fully seated.

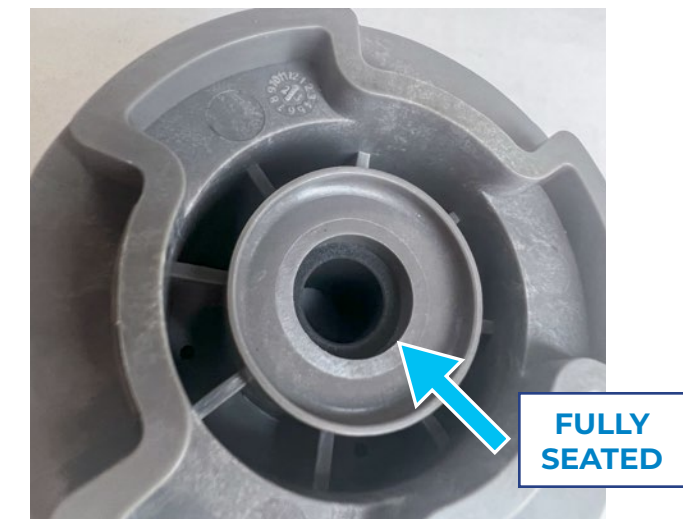
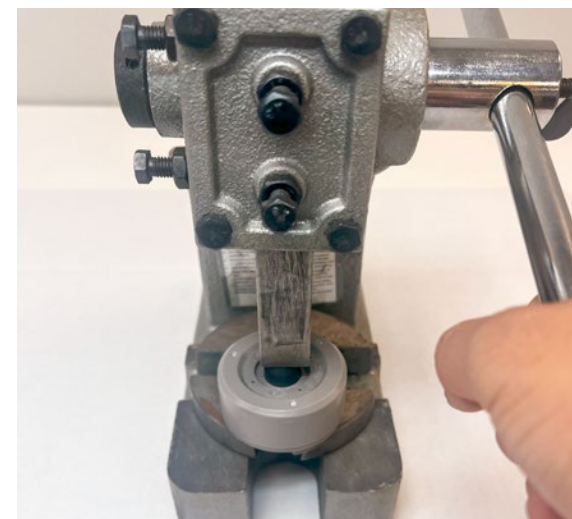

## WEAR KIT

- To remove the thrust ring, cut a small section out of the thrust ring using a side cutter.



- Pull the thrust ring out of the impeller. Pliers may be used if needed.
- Line up the flat sides of the new replacement thrust ring with the impeller with the wear notches facing up and press down until the thrust ring is fully seated.



- Follow steps 6 – 9 of the pump reassembly instructions (pages 20 – 21) to reassemble the pump.

## IMPELLER KIT

### IMPELLER/IMPELLER MAGNET REPLACEMENT

If the impeller or impeller magnet requires replacement, follow the instructions below to install the Impeller Kit (sold separately).

- Follow steps 1 – 9 of the pump disassembly and inspection instructions (pages 14 – 17).
- Remove the impeller assembly by pulling straight up.



- Carefully install the new impeller assembly by sliding it over the impeller shaft in the barrier.



- Follow steps 6 – 9 of the pump reassembly instructions (pages 20 – 21) to reassemble the pump.

## WET END KIT

### WET END REPLACEMENT

Follow the instructions below to install the Wet End Kit (sold separately). This kit includes the pump wet-end assembly that attaches to the motor adapter.

1. Follow steps 1 – 4 of the pump disassembly and inspection instructions (pages 14 – 15).
2. Remove the bolts and washers securing the wet-end assembly to the motor adapter.

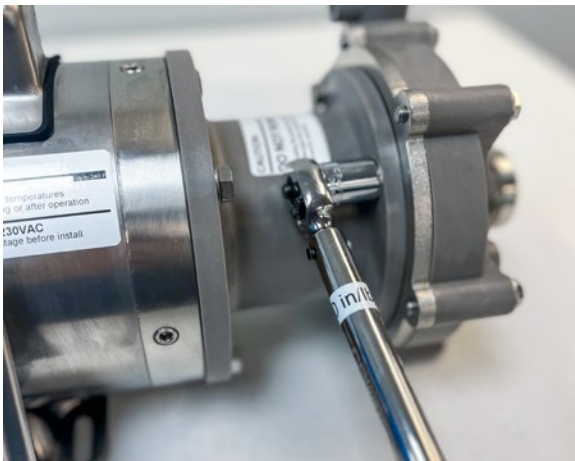

3. Pull straight out to disengage the wet-end assembly from the motor adapter.

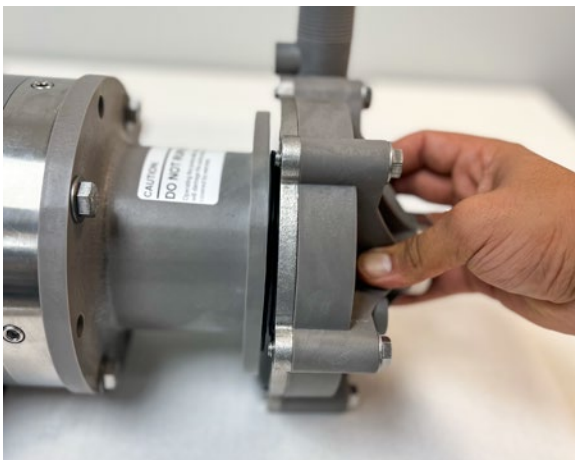

## WET END KIT

4. Replace the O-ring on the motor adapter if needed. Silicone grease, such as Super Lube, may be optionally applied to the O-ring.

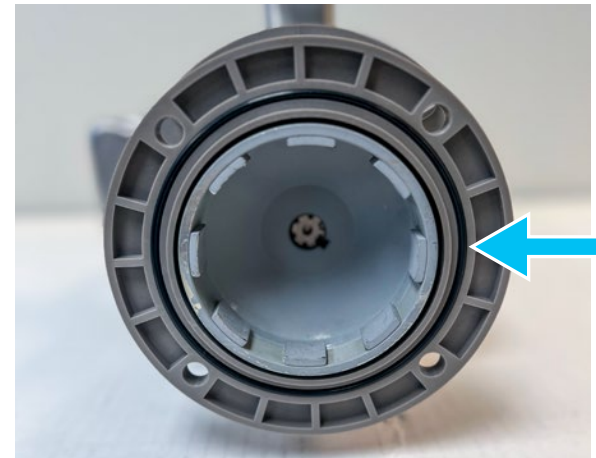

5. Align the holes on the replacement pump wet-end assembly with the holes on the motor adapter.
6. Reinstall the bolts and washers and tighten evenly using a star pattern. Before installing each bolt, use Loctite 242 or equivalent. Tighten to 60 in-lb (6.8 N-m).

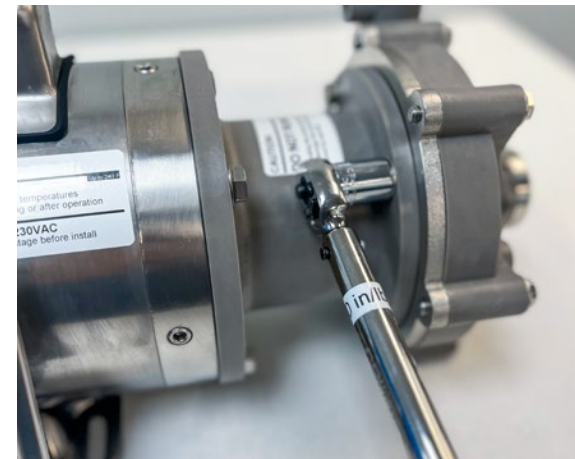

## MOTOR KIT

### MOTOR REPLACEMENT

To replace an existing motor, follow the instructions below:

**WARNING:** Keep away from metallic particles, tools, and electronics. Drive magnets **MUST** be free of metal chips.

**WARNING:** Keep the drive magnet away from the open end of the motor adapter and barrier. Strong magnetic attraction could allow the drive hub to enter the motor adapter, resulting in injury or damage.

1. Follow steps 1 – 6 of the pump disassembly and inspection instructions (pages 14 – 15).
2. Replace the O-ring on the motor adapter/pump-end assembly if needed. Silicone grease, such as Super Lube, may be optionally applied to the O-ring.

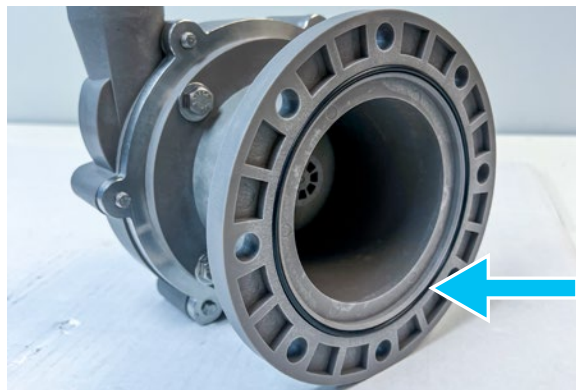

3. Align the holes on the pump-end assembly with the holes on the motor.

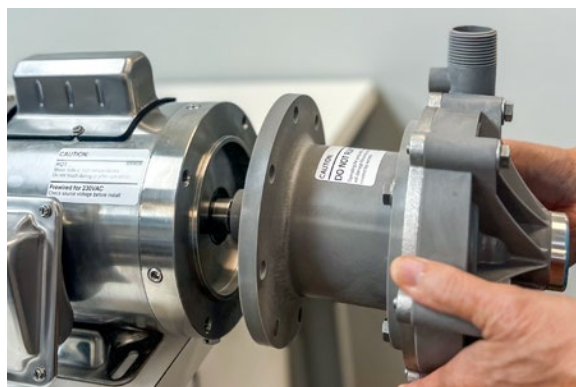

4. Reinstall the bolts and washers and tighten evenly using a star pattern. Before installing each bolt, use Loctite 242 or equivalent. Tighten to 60 in-lb (6.8 N-m).

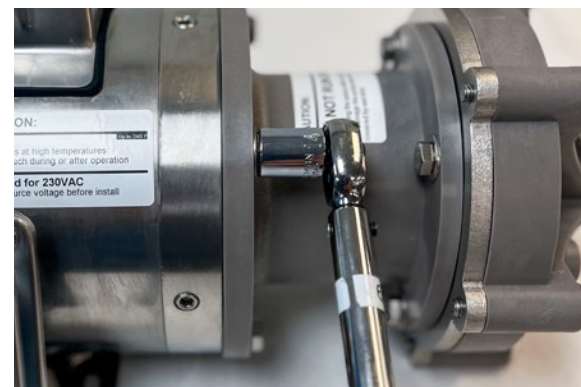

## PUMP DIAGRAMS

SB-030M, SB-045M, SB-062M, SB-075M & SB-100M

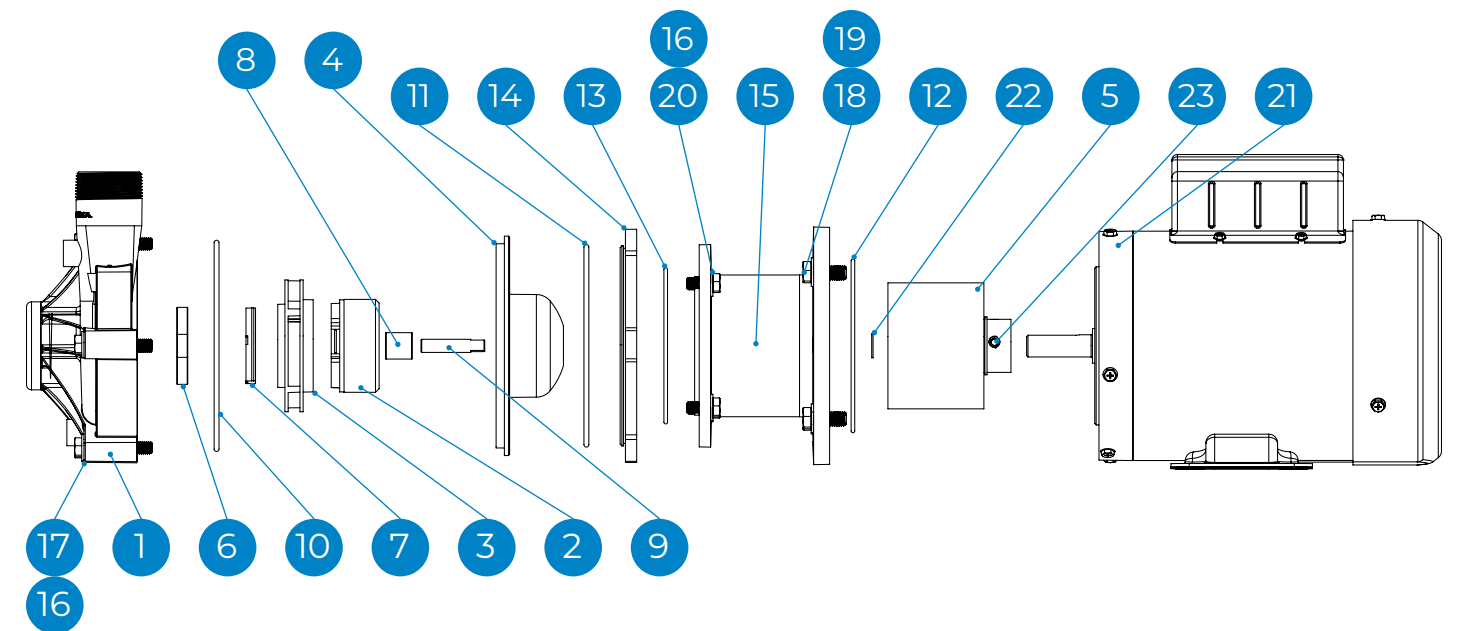

SB-137M

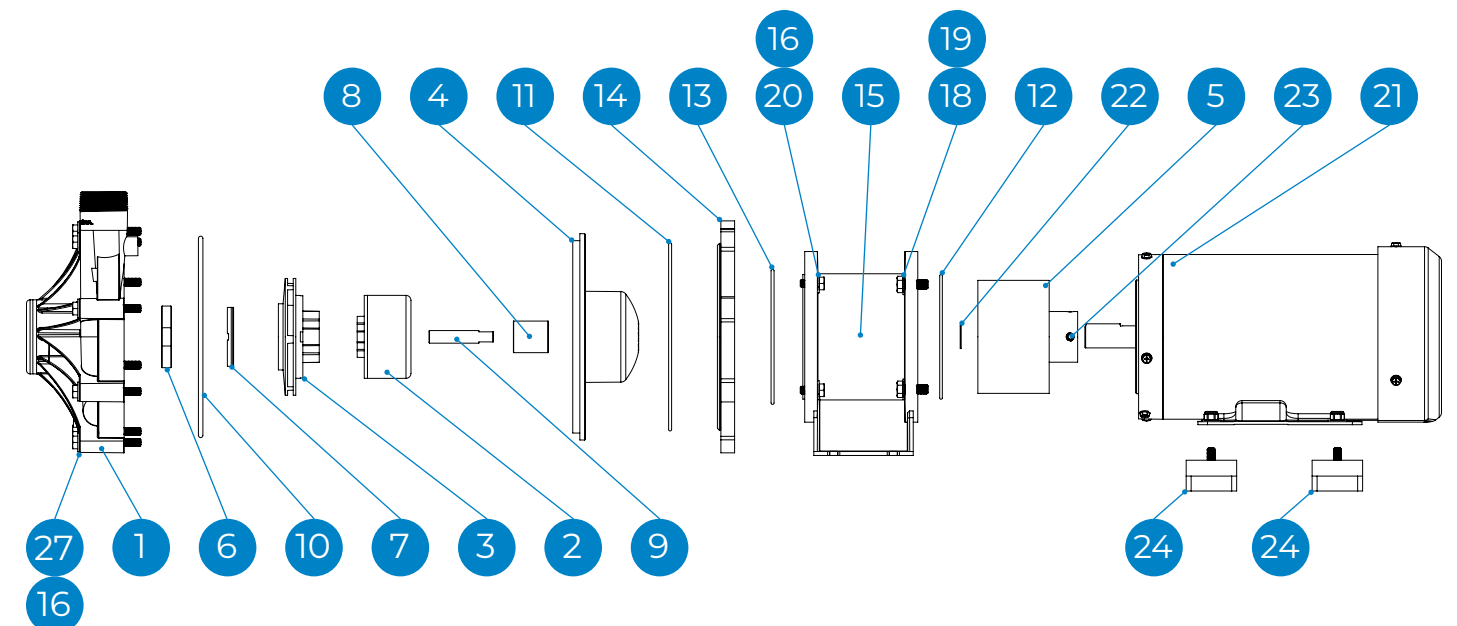

## PUMP DIAGRAMS

SB-150M

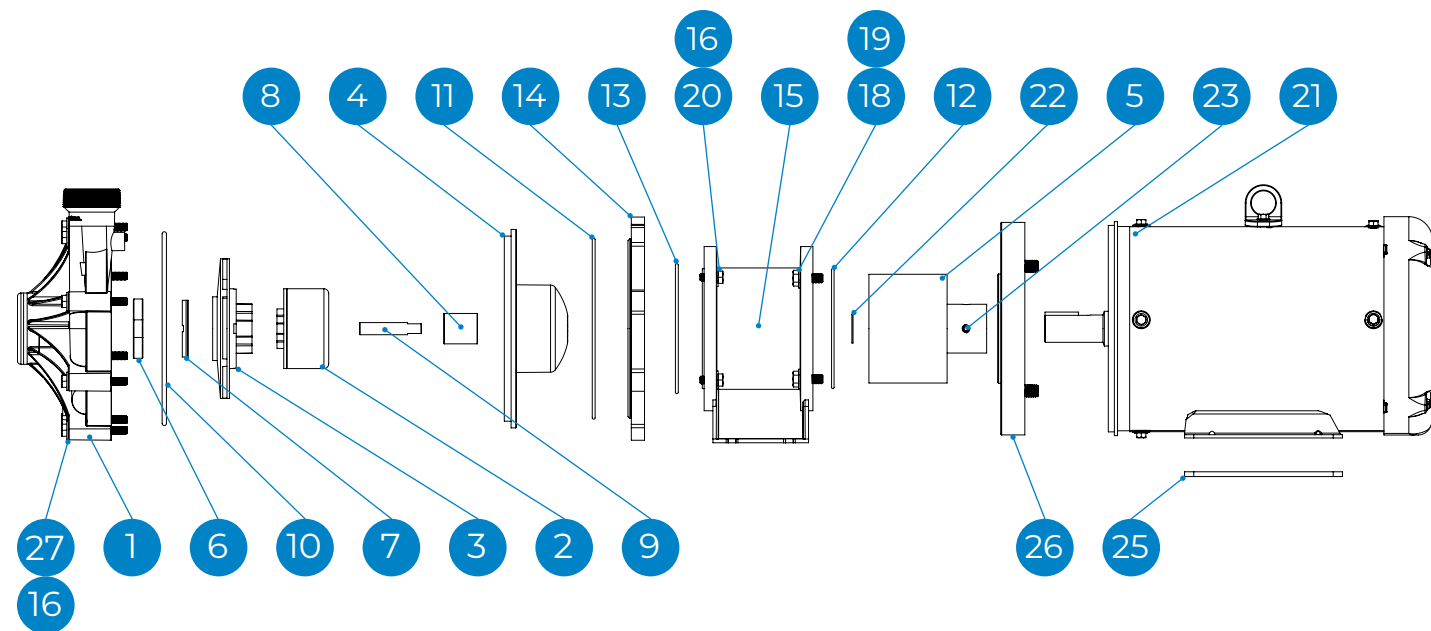

## PART LIST

ITEM NO.	PART NAME
1	PUMP FACE
2	IMPELLER MAGNET
3	IMPELLER
4	BARRIER
5	MAGNETIC SHAFT COUPLER
6	PUMP FACE THRUST RING
7	IMPELLER THRUST RING
8	IMPELLER BUSHING
9	IMPELLER SHAFT
10	O-RING, BARRIER
11	O-RING, BASE PLATE
12	O-RING, MOTOR
13	O-RING, MOTOR ADAPTER
14	BASE PLATE

ITEM NO.	PART NAME
15	MOTOR ADAPTER
16	WASHER, 5/16
17	BOLT, HEX, 5/16 X 2 IN
18	BOLT, HEX, 3/8 X 1 IN
19	WASHER, 3/8
20	BOLT, HEX, 5/16 X 3/4 IN
21	MOTOR
22	RETAINING RING
23	SET SCREW
24	MOTOR MOUNT, SMALL
25	MOTOR MOUNT, LARGE
26	ADAPTER PLATE
27	BOLT, HEX, 5/16 X 2.5 IN



**Contact ElectroSea for service or spare parts.**

Service: [support@electrosea.com](mailto:support@electrosea.com) | (561) 257-5739

Sales: [sales@electrosea.com](mailto:sales@electrosea.com) | (952) 475-8084

**ELECTROSEA®**  
EXPERTS IN MARINE GROWTH PREVENTION SYSTEMS®

© 2023 ElectroSea. All Rights Reserved.

ElectroSea's products are designed, assembled and quality-control tested at our headquarters in Minneapolis, Minnesota, USA.



(888) 384-8881  
(952) 475-8084



[www.electrosea.com](http://www.electrosea.com)

U.S. and Foreign Patents Pending  
750075-004