

# CLEARLINE® System



## Installation Manual

## Model CL-1000-X1.5



(888) 384-8881  
(952) 475-8084



support@electrosea.com  
www.electrosea.com

# ELECTROSEA®

## Introduction

|   |   |
|---|---|
| Table of Contents                               | 2 |
| ElectroSea® and ClearLine® System               | 3 |
| Components                                      | 4 |
| Safety Considerations                           | 5 |
| Pre-Installation Descaling of Seawater Conduits | 5 |

## Optimal Performance & Maintenance

|                                    |   |
|------------------------------------|---|
| Optimal Performance and Flow Alert | 6 |
| Internal Screen and Cell Indicator | 7 |

## Installation Overview

|                                |   |
|--------------------------------|---|
| Electrical Connection Overview | 8 |
| Seawater Connection Overview   | 9 |

## ClearCell® Canister Installation

|                                    |       |
|------------------------------------|-------|
| ClearCell Canister Preparation     | 10    |
| Mounting Options                   | 11    |
| ClearCell Canister and Flow Sensor | 12-13 |
| Strainer Return Line               | 14    |
| ClearCell Canister Reassembly      | 15    |

## Control Unit Installation

|                                  |       |
|----------------------------------|-------|
| Control Unit Mounting and Wiring | 16    |
| Control Unit Wiring to Inhibit   | 17    |
| Pump Mode and Time               | 18    |
| Pump-Control Wiring              | 19    |
| Example Pump-Control Schematics  | 20-21 |

## Important Information

|                |    |
|----------------|----|
| Specifications | 22 |
|----------------|----|

### COPYRIGHT © 2020

*No part of this publication may be reproduced, translated, stored in a retrieval system, or transmitted in any form or by any means electronic, mechanical, photocopying, recording, or otherwise without the prior written consent of ElectroSea, LLC. Every precaution has been taken in the preparation of this manual to ensure its accuracy. ElectroSea assumes no responsibility for errors and omission. Neither is any liability assumed for damages resulting from the use of this product and information contained herein.*

## Warranty Policy

Please visit our website at [www.electrosea.com/warranty](http://www.electrosea.com/warranty) to view our full warranty terms and conditions.

## ELECTROSEA®

---

ElectroSea was created when the owners of a sportfishing vessel invented “a better way” to prevent biofouling in their seawater cooling system. Solving complex technical problems is our expertise. With more than 100 issued U.S. patents and 350+ foreign patents in advanced technologies, our executive management team has been developing innovative solutions for more than 50 years. With an expert team of “old salts” who eat, sleep, and breathe boating, ElectroSea will improve your time on the water.

## CLEARLINE® System

---

ClearLine is an innovative marine electrochlorination system that prevents biofouling and barnacle growth in your vessel’s seawater lines. ClearLine keeps your air conditioners, chillers, and refrigerators operating at maximum flow rates and your sea strainers clean longer. The patented ClearLine System includes the ClearLine Control Unit, which is the brain, and the ClearCell®, which is the heart of the system. ClearLine operates automatically 24x7x365 and is built for flawless and reliable performance.

### Quick Start Installation Guide, Installation Manual and Operation Manual

**The ClearLine System includes a detailed Quick Start Installation Guide, Installation Manual, and Operation Manual. READ all manuals in their entirety before proceeding with installation.**

## Components

The ClearLine System includes the Control Unit, ClearCell Canister, and all components listed below:

### Control Unit

- (1) Control Unit
- (5) Cables
  - (1) Power: 20' (6.1 m)
  - (1) ClearCell: 12' (3.7 m)
  - (1) Flow Sensor: 12' (3.7 m)
  - (1) Inhibit: 9' (2.7 m)
  - (1) Pump: 9' (2.7 m)
- (4) Mounting Screws #10 x 1" (2.54 cm)

### ClearCell Canister

- (1) ClearCell
- (1) Flow Sensor
- (1) Union
- (3) Hose Connectors
- (1) Top-Side Mounting Bracket
- (1) Bottom-Mounting Bracket
- (4) Mounting Screws #12 x 1.25" (3.18 cm) Round Head
- (4) Mounting Screws #12 x 1.25" (3.18 cm) Flat Head
- (4) Machine Screws M5 x 12 mm Round Head

### Items Not Included

- Optional Base-Tab Bracket
- Optional Strainer Accessory Kit
- Marine-Grade Seawater Hose
- Stainless-Steel Hose Clamps
- PTFE Tape and Paste
- Other Fittings



Major components are shown above.

### Safety Considerations

Improper installation can result in unsatisfactory performance, premature failure, and damage to systems in the seawater circuit and/or to the vessel.

- WARNING** Indicates a hazardous situation that, if not avoided, could result in death or serious injury.
- CAUTION** Indicates a hazardous situation that, if not avoided, could result in minor or moderate injury.
- NOTICE** Indicates a hazardous situation that can cause damage to personal property, the environment, or equipment.

### Pre-Installation Descaling of Seawater Conduits

Pre-installation descaling ensures any existing biofouling that has accumulated on the interior seawater lines are removed. If seawater lines are impacted with barnacles and marine growth, then ElectroSea recommends professional descaling prior to installing the ClearLine System. By starting with descaled and clean seawater lines, you will realize the full benefit of the ClearLine System. For new vessels, descaling is not necessary.

**NOTICE** **DO NOT perform acid descaling after the ClearLine System has been installed. Descaling acids will damage the ClearCell Canister and ClearCell Electrode and void the warranty.**



▶ **Without ClearLine**

- **Hours** - Complex multispecies microbial biofilm forms.
- **Days** - Secondary colonizers arrive and multiply.
- **Weeks** - Macroscopic communities of algae and invertebrates grow.



▶ **With ClearLine**

The advanced ClearLine electrochlorination system continuously prevents barnacles and biofilm build-up.

## Optimal Performance

**Constant Chlorinated Seawater Flow:** The ClearLine System should be powered ON and have seawater flowing through the ClearCell Canister whenever possible. This provides the vessel's seawater circuit with constant chlorinated seawater to prevent unwanted marine growth. Intermittent or stagnant seawater that is not continuously electrochemically treated allows growth of marine microorganisms. Barnacles have the innate ability to close themselves off and survive intermittent exposure to biocidal agents:

- DO NOT turn off seawater pumps, air conditioner, or chillers for an extended period of time.

Inspect the vessel for problem areas:

- Pre-existing biofouling in seawater lines prior to ClearLine installation
- Clogged seawater strainers and intakes
- Impacted, blocked, or occluded lines from debris lodged in plumbing
- Sporadic demand valve areas (Depending on the system, valves that turn on and off can foster unwanted marine growth.)

## Flow Alert

**Flow Alert:** The Flow Alert feature monitors seawater flow through the ClearCell. This feature allows the user to set a minimum seawater flow rate threshold value and time duration. If the seawater flow rate drops below the minimum value for a period of time, "FLOW ALERT" will flash on the display (no audible alert).

This feature notifies the user that some part of the seawater circuit, such as the intake, strainer, pump, or internal screen on the ClearCell, requires cleaning or is not functioning properly. Flow rate can be set in GPM or LPM, with the time duration set in minutes. To set the Flow Alert value, go to Menu, Flow Alert and enter the desired threshold flow rate and time duration for notification.

**NOTICE** The Flow Alert feature is OFF by default and must be set up by the installer or end user.

**NOTICE** ClearLine will continue generating chlorine even after a Flow Alert occurs. Flow Alert does not prevent ClearLine from operating.

If a Flow Alert occurs

1. Check vessel's strainers and intake grates for blockage or debris.
2. Check seawater pump operation.
3. Check ClearCell Internal Screen. (Refer to the operation manual for instructions.)

>

|             |         |
|-------------|---------|
| -Flow Alert | -Update |
| -Display    |         |
| -Cell       |         |
| -Default    | -Exit   |

## Internal Screen

**Internal Screen:** The ClearCell contains an internal screen to catch debris (tiny shells or other foreign materials that pass through the vessel's main strainer) before it reaches the flow sensor. The internal screen should be cleaned periodically and whenever debris gets caught in the screen and decreases seawater flow. Refer to the operation manual for detailed instructions on cleaning the internal screen.

### NOTICE

- **DO NOT PERFORM ACID DESCALING OF THE SEAWATER CIRCUIT AFTER THE CLEARLINE SYSTEM HAS BEEN INSTALLED.**
- **DESCALING ACIDS OR CLEANING CHEMICALS WILL DAMAGE THE CLEARCELL CANISTER AND CLEARCELL ELECTRODE AND VOID THE WARRANTY.**
- **DO NOT TOUCH THE CLEARCELL ELECTRODE PLATES OR USE ANY TYPE OF MECHANICAL BRUSH.**
- **THE CLEARCELL ELECTRODE PLATES CONTAIN A SPECIAL METAL-OXIDE COATING THAT WILL BE PERMANENTLY DAMAGED IF YOU HANDLE IT.**

### NOTICE

Low seawater flow may damage the cooling system and other components that depend on this water for proper operation. It is the owner's responsibility to monitor the vessel's seawater flow and perform any maintenance on the vessel's seawater pumps, strainers, and internal screen on the ClearCell.

## Cell Indicator

**Cell Indicator:** The Control Unit will display "SALINITY/CELL," "% OUTPUT," and illuminate the red Cell LED in various conditions. This is not an immediate cause for concern and may be temporary depending on seawater salinity level. ClearLine will continuously attempt to generate chlorine and automatically resume standard operation when conditions are resolved. The Cell Indicator will be illuminated if any of the following conditions occur:

- Water salinity is below 20 parts per thousand. (This is the most common cause of a ClearLine Cell Indicator notice.)
- ClearCell Cable or its connectors have been compromised.

Refer to the operation manual for Cell Indicator troubleshooting.

**Spray screen with fresh water to remove debris.**

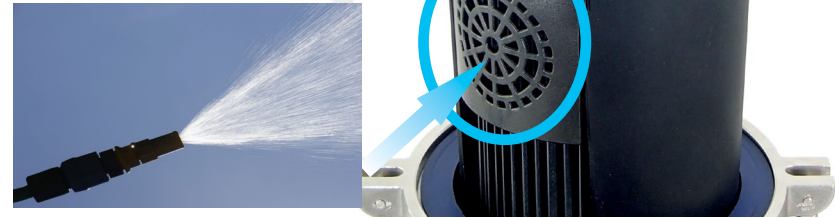

## Electrical Connection Overview

- The ClearLine Control Unit must be located:
  - Within 12 feet (3.7 m) of the ClearCell Canister
  - Within 12 feet (3.7 m) of the Flow Sensor
  - Within 20 feet (6.1 m) of the 24-VDC power source

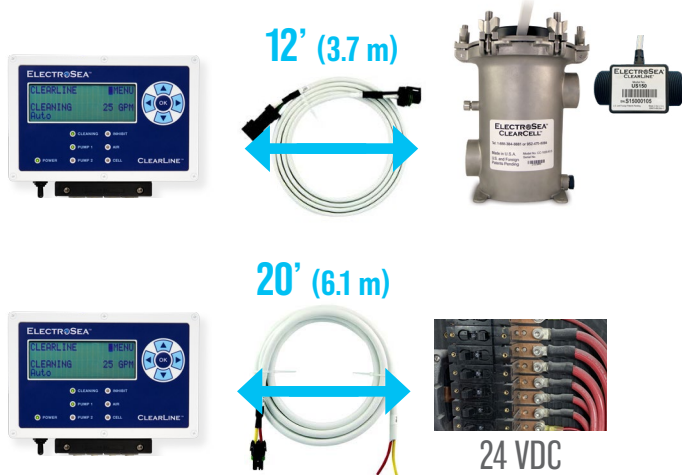

**NOTICE** DO NOT cut, extend, or splice the ClearCell Cable. Longer ClearCell Cable are available from ElectroSea.

**NOTICE** DO NOT connect multiple ClearCell Cables together. The ClearCell Extended Cables in the table below show the total cable length from the ClearLine Control Unit to the ClearCell.

Modification of the ClearCell Cable will impair ClearLine operation.

OPTIONAL CABLE ACCESSORIES:

| PART NUMBER       | DESCRIPTION                          |
|-------------------|--------------------------------------|
| CBL01-CC-EXT-15FT | 15' (4.6 m) ClearCell Extended Cable |
| CBL01-CC-EXT-20FT | 20' (6.1 m) ClearCell Extended Cable |

- The ClearCell Canister must be connected to the vessel's bonding circuit.

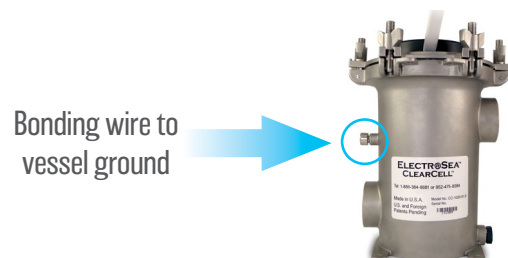



## Seawater Connection Overview

1. Locate the vessel's seawater intake pump, strainer, and seacock shut-off valves.
2. Turn OFF ALL seacock shut-off valves in the seawater circuit at or below the waterline. This includes any output seacocks to prevent back siphoning.
3. The ClearCell should be installed **after the seawater strainer and pump** and **before** any seawater-cooled equipment, such as air conditioners, chillers, etc. The ClearCell should be installed at or below the waterline.
4. The ClearLine-treated strainer return line should be connected **after** the ClearCell Flow Sensor output and before the strainer and after the seacock.

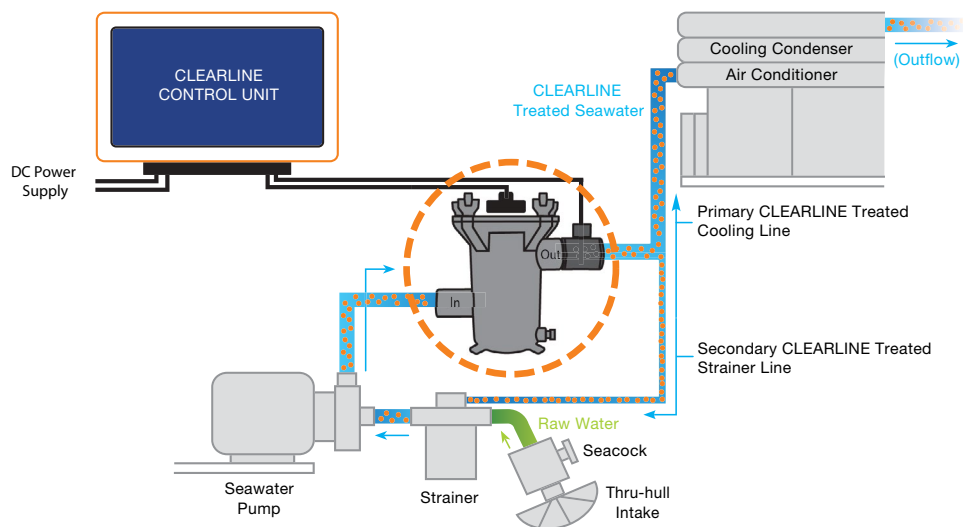

**WARNING** DO NOT USE DESCALING SOLUTIONS, ACIDS, OR CLEANING CHEMICALS AFTER CLEARLINE HAS BEEN INSTALLED. THIS WILL DAMAGE THE CLEARLINE SYSTEM AND VOID THE WARRANTY.

**WARNING** Before beginning the ClearLine System installation, turn OFF all seacock valves in the seawater circuit.

**WARNING** Use marine-grade hose and double clamp with two stainless-steel clamps, reversing the clamps. Failure to properly secure seawater connections could result in sinking the vessel.

**WARNING** DO NOT exceed the ClearCell pressure specifications.

**WARNING** All seawater plumbing connections must be performed by a qualified marine installation professional.

**NOTICE** DO NOT decrease seawater flow below the manufacturer's specifications for downstream cooling equipment.

**NOTICE** Limit the use of 90° elbows as they restrict flow and cause pressure drop.

**NOTICE** The ClearCell Canister is made of 2205 Duplex Stainless Steel for corrosion resistance. Do not connect dissimilar metals to it if possible.

**NOTICE** Use only original parts supplied by ElectroSea. They are made of special titanium, stainless, and other high-quality materials. Use of non-factory or substitute parts will void the warranty.

## ClearCell Canister Preparation

1. Unsecure the pressure ring by turning the wing nuts counterclockwise.
2. Remove the pressure ring.
3. Remove the Electrode Assembly by lifting it straight up by the sides of the black plastic top. Do not lift or pull on the top cable connectors. Set the assembly aside in a safe location.

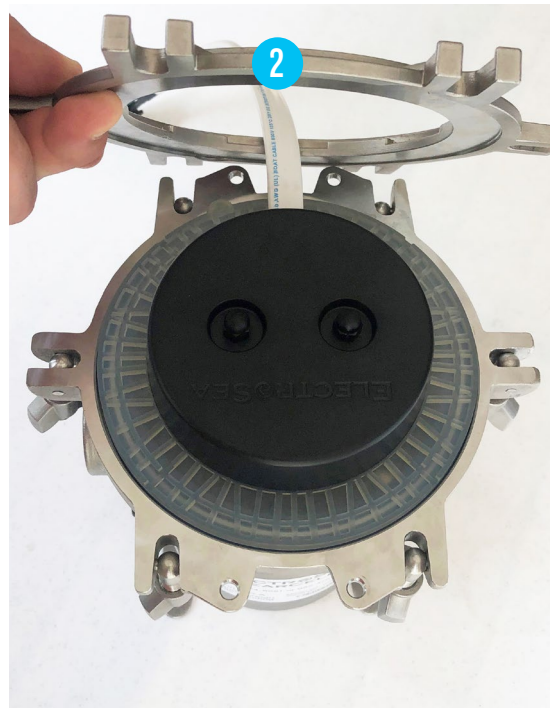
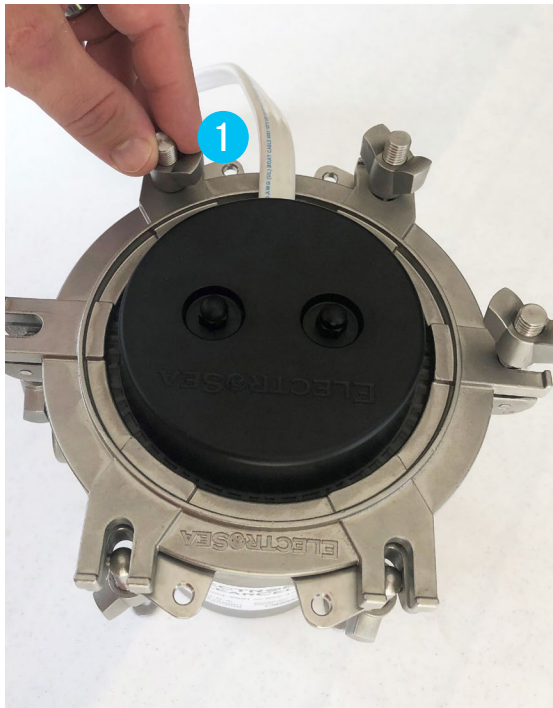

## Mounting Options

1. The ClearCell Canister must be installed so it is level and at or below the waterline.

**WARNING** Failure to mount the ClearCell Canister level could result in the accumulation of harmful gas.

2. The ClearCell Canister can be mounted using several different options as shown below:



**Mount ClearCell Canister Level**

### OPTION A

#### Base-Tab Mounting



1. Mount the ClearCell Cister to a flat, interior engine-room surface.
2. Insert (4) #12 round head screws into base tab to secure the ClearCell Canister.

**WARNING** Do not screw through the hull of the boat.

### OPTION B

#### Side Mounting

**Top Bracket**

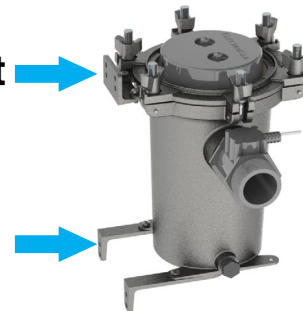

**Bottom Bracket**

1. Attach top and bottom side-mount brackets to the ClearCell Canister with (4) M5 machine screws.
2. Secure to a stringer or other appropriate load-supporting vertical surface with (4) #12 round head screws and (4) #12 flat head screws.

### OPTION C

#### Base-Tab Extension Bracket (optional mounting accessory)

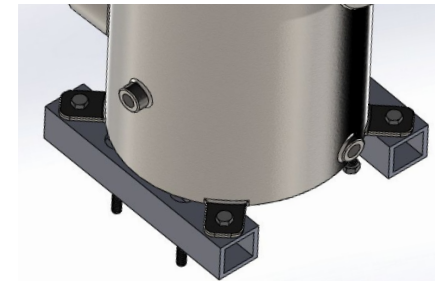

1. Mount the ClearCell Canister on the Base-Tab Extension Brackets.

| PART NUMBER | DESCRIPTION   |
|-------------|---|
| BTEB-5.5    | Extension bracket that connects to mounting feet tabs on ClearCell Canister |

## ClearCell Canister and Flow Sensor

1. The ClearCell and Flow Sensor have directional INPUT and OUTPUT requirements. Seawater MUST enter at the INPUT port and flow through the ClearCell Canister and Flow Sensor according to the marked labels.

**NOTICE** Failure to route seawater in the direction of the ClearCell Canister and Flow Sensor INPUT and OUTPUT labels will result in improper operation of the ClearLine System.

2. Connect the Flow Sensor **after** the ClearCell Canister output port. The Flow Sensor is made of glass-filled nylon for superior strength; however, this makes the threads less malleable and rougher than other plastics. When sealing to this component, it is recommended that multiple turns of PTFE tape and paste are used.

- 4x turns of Hercules® MEGATAPE™ PTFE or equivalent
- Hercules® REAL-TUFF™ Thread Sealant or equivalent

**NOTICE** **DO NOT** place 90° elbows or other flow-restrictive plumbing fittings **BEFORE** the Flow Sensor. This will alter the measured flow and cause improper operation of the ClearLine System.

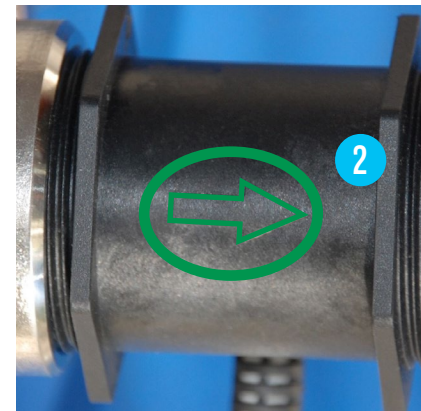
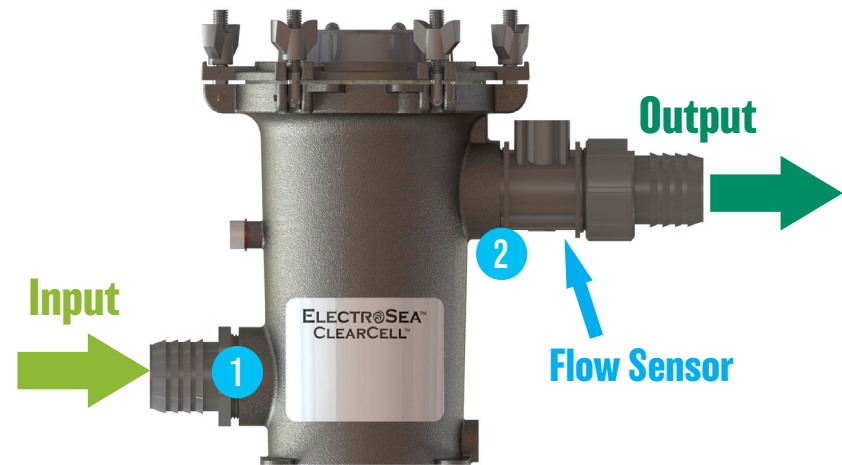
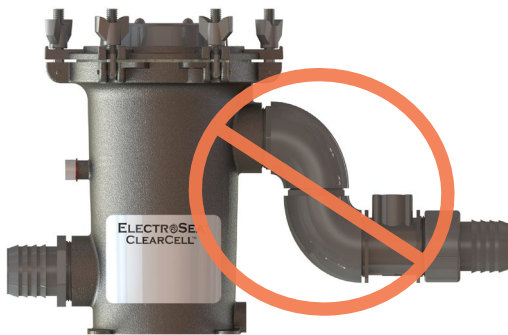

The Flow Sensor must be oriented so seawater follows direction of the flow arrow.

## ClearCell Canister and Flow Sensor

3. Connect the threaded female PVC hose connector to the Flow Sensor output. Use PTFE tape and thread sealant.
4. Connect male PVC hose connector to threaded Union. The Union provides quick access to the Flow Sensor as necessary. Use PTFE tape and thread sealant.
5. Add flexible hose of desired length and join the hose connector on the Flow Sensor output to the hose connector on the Union. Use two hose clamps (not included), reversing the clamps over the flexible hose connections.

**WARNING** Failure to use hose clamps could result in a seawater leak or hose disconnection causing damage to property and/or the vessel sinking.

6. Add a flexible hose hanger, hose strap, or hose-support bracket within 12" (30.5 cm) of the Flow Sensor. Make sure the Flow Sensor and Union are properly supported.

**WARNING** DO NOT let the weight of the hose or any plumbing hang unsupported on the Flow Sensor. Use hose hangers, hose straps, or hose-support brackets that are attached securely to a bulkhead, stringer, or other solid object to relieve any force on the Flow Sensor when connected to the ClearCell Canister. Excessive force could crack the Flow Sensor and/or Union.

**NOTICE** All seawater flowing through the ClearCell must flow through the Flow Sensor. DO NOT split or divert seawater before the Flow Sensor.

### Flow Sensor Connected to ClearCell Canister

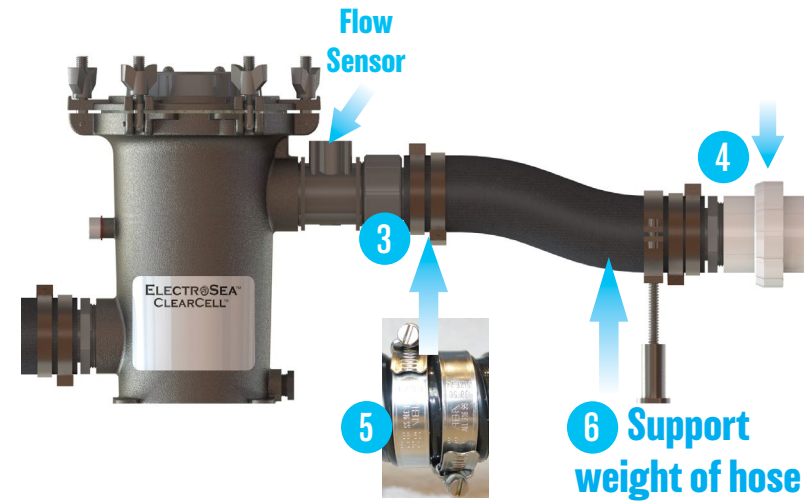

### Option with Flow Sensor Connected to Union

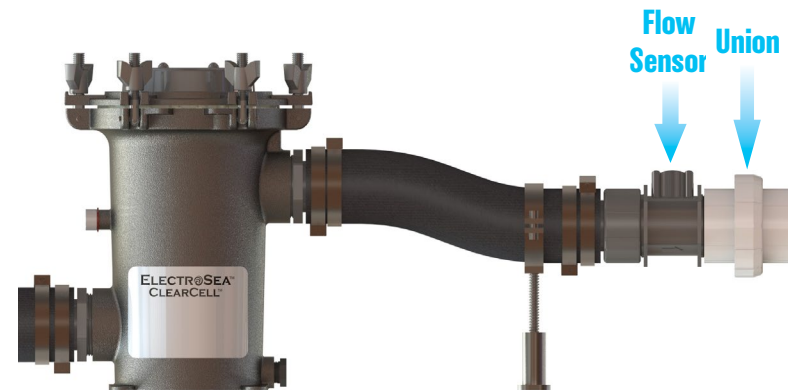

## Strainer Return Line

1. Add a ClearLine-treated strainer return line that goes back to the strainer with a tee-fitting and ball valve after the ClearCell Flow Sensor. This ClearLine-treated strainer return line should be connected **after the ClearCell Flow Sensor output** and return to the strainer lid or after the seacock. The ClearLine-treated strainer return line should be **1/2" (1.3 cm) ID** flexible hose and include a ball valve to adjust return flow as necessary.

**NOTICE** DO NOT connect the return line source before the pump on the suction side.

2. There are two options to install the ClearLine-treated return line to the strainer:
  - 2A. Use the ClearLine Strainer Accessory Kit to plumb the return line directly to the top of the strainer lid. The ClearLine Strainer Accessory Kit includes a custom strainer lid, ball valve, tubing, connectors and fittings.

**WARNING** DO NOT drill through the top of any strainer lid. The lid will crack and/or fail over time and could result in sinking of the vessel.

- 2B. Use the appropriate plumbing fittings to connect the return line after the seacock and before the strainer. Make sure to use a ball valve.

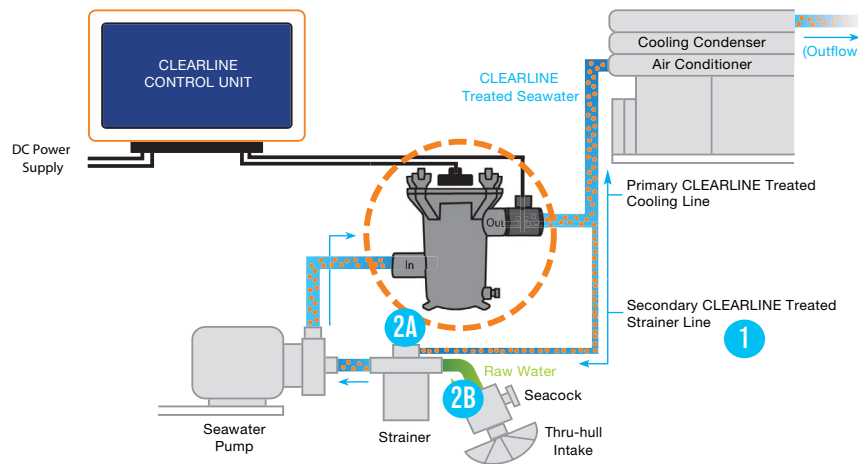

2A

| PART NUMBER | DESCRIPTION  |
|-------------|--|
| DSA-1.5     | Arctic Steel 1.5" (3.8 cm) Dual Strainer Accessory |
| DSA-SP1     | SCOT Pump Dual Strainer Accessory                  |

## ClearCell Canister Reassembly

1. Ensure the gasket is in the top of the ClearCell Canister.
2. The Electrode Assembly and lid are keyed and can be inserted in only one direction. The plates of the ClearCell Electrode will be parallel to the seawater input. Align the Electrode Assembly and insert it into the ClearCell canister.

**NOTICE** DO NOT touch the metal ClearCell Electrode surface with your hands or any metal tools. The ClearCell Electrode has a proprietary coating. This may damage the ClearCell Electrode and affect its performance.

**NOTICE** DO NOT use chemicals, acids, descaling solutions, or zincs in the ClearCell Canister or on the ClearCell Electrodes. This will damage the ClearCell Electrode and Canister.

3. Add the pressure ring and tighten down the wing nuts evenly. Do not use tools to perform this tightening process. Work in a star pattern so they are evenly secure.
4. Double-check that all fittings, hose clamps, and wing nuts are secure. Open the seacock valves and verify there are no leaks.
5. Bleed excess air from the ClearCell Canister, then re-tighten wing nuts.

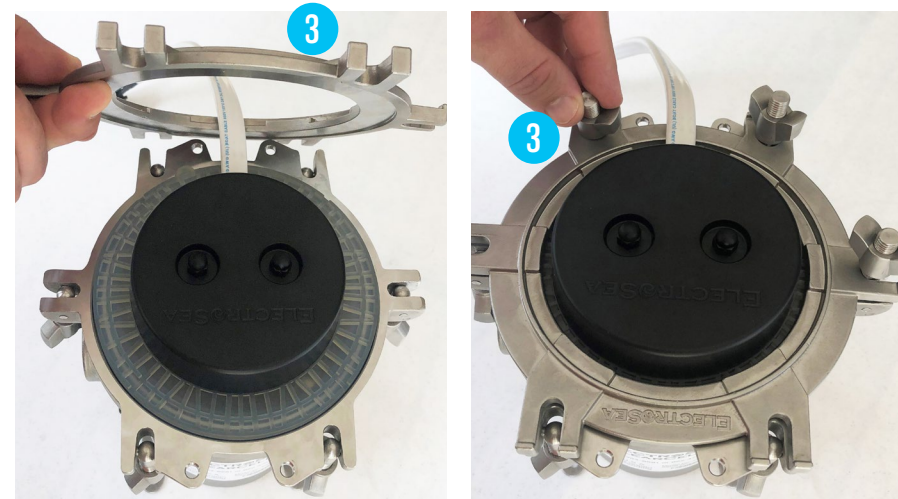

## Control Unit Mounting and Wiring

### Location and Mounting

- Mount the ClearLine Control Unit (1) on a bulkhead in the engine room using the four #10 stainless-steel Mounting Screws provided. ClearLine is designed for marine engine rooms with a maximum environmental temperature of 122 °F (50 °C). Do not mount the Control Unit in an area that receives excessive heat.

### Control Unit to 24-VDC Power Supply

- Power OFF the ClearLine Control Unit (2) before beginning the wiring process below.
- Locate an always-on, 24-VDC power source on the vessel. Connect the **RED (+)** and **YELLOW (-)** wires of the Power Cable to this source according to the appropriate electrical standards (i.e., ABYC). Connect the Power Cable (A) to the Control Unit.

**NOTICE** Failure to Power OFF the ClearLine Control Unit during the wiring process could result in damage to the ClearLine System.

### Control Unit to ClearCell Canister

- Connect the ClearCell Cable (B) between the Control Unit and the ClearCell Canister.

### Control Unit to Flow Sensor

- Connect the Flow Sensor Cable (C) to the Control Unit and the Flow Sensor.

### ClearCell Canister Bonding

- Connect vessel bonding wire to the ClearCell Canister bonding terminal according to appropriate bonding standards (i.e., ABYC).

**NOTICE** Failure to bond ClearCell will void the warranty.

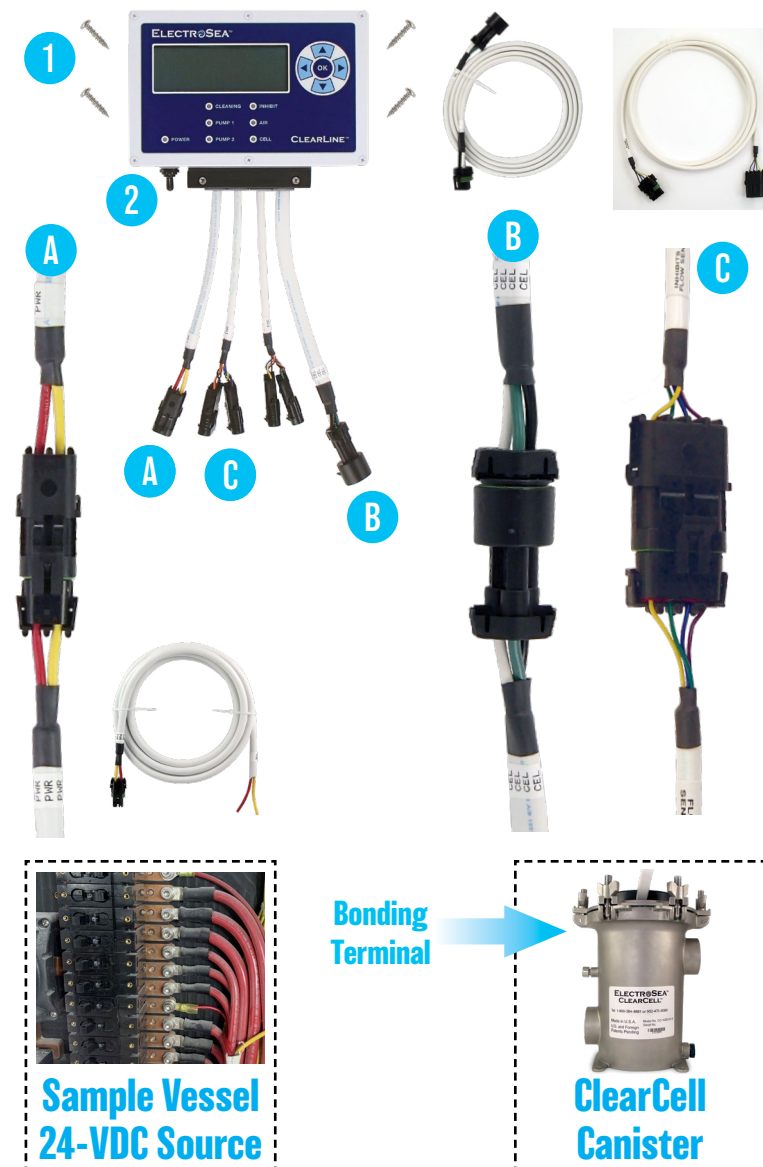



## Control Unit Wiring to Inhibit

### ClearLine to Inhibit Lines (Reverse Osmosis Water System and Baitwell)

The ClearLine can be wired to receive a signal from one (1) 24-VDC or 12-VDC and one (1) 240-VAC or 120-VAC input from equipment, such as a baitwell or reverse osmosis (RO) system, that are not compatible with chlorine. These wired inputs trigger the ClearLine System to “inhibit” (stop) generating chlorine. This is an optional feature and is not required for operation.

1. Locate the baitwell or RO water system controls. See the table below for connection.

| Power Type         | Wire Color      |
|--------------------|-----------------|
| 24 VDC or 12 VDC   | Black and Brown |
| 240 VAC or 120 VAC | Red and Orange  |

2. Connect the Inhibit Cable (D) to the ClearLine Control Unit and the designated RO water system or baitwell equipment.

**NOTICE** Reverse osmosis (RO) system membranes are easily damaged by chlorine in the feed water. **DO NOT CONNECT THE CLEARLINE SYSTEM TO AN RO SYSTEM UNLESS THE INHIBIT WIRES ARE CONNECTED TO TURN THE CLEARLINE OFF WHEN THE RO SYSTEM IS OPERATING.**



D

D



**BAITWELL**

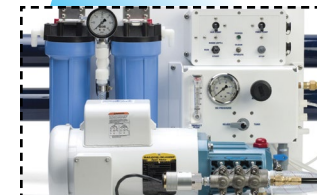

**RO WATER MAKER**

## Pump Mode and Time

Pump Mode and Time are optional features not required for ClearLine to operate properly. Refer to the operation manual to set the Pump Mode and Time.

**Pump Mode:** The Pump Mode should be set up during the installation process. Refer to the table below to verify the Pump Mode is set correctly. Use the Up or Down arrow to select Pump Mode.

| Mode                                  | Description  | Wiring Required |
|---------------------------------------|--|-----------------|
| <b>Pump Sense Not Used</b>            | Pump sensing is not being used. This is the factory default mode. <i>(Note: If your vessel does not have dual pumps and/or cannot be connected to the ClearLine System's automatic pump-cycling feature, then set Pump Mode to "Pump Sense Not Used").</i> | No              |
| <b>Pump#1 and Pump #2 Alternating</b> | Two seawater intake pumps are wired to the ClearLine System. Pump #1 and Pump #2 can be alternated at a specific time duration from 10 minutes to 72 hours. The ClearLine is controlling the ON/OFF operation of both pumps.                               | Yes             |
| <b>Pump#1 and Pump #2 Monitors</b>    | Two seawater intake pumps are wired to the ClearLine System. Pump #1 and Pump #2 can be monitored. The ClearLine is only monitoring and NOT controlling the ON/OFF operation of both pumps.  | Yes             |
| <b>Pump #1 ONLY Monitor</b>           | One seawater intake pump is wired to the ClearLine System. Pump #1 is used for monitoring purposes only.   | Yes             |

**Pump Time:** This is an optional feature for vessels that have dual seawater intake pumps that are manually cycled. This feature sets the desired duration of time that Pump #1 or Pump #2 operates. The Pump Time can be set to 10 minutes or 1-hour intervals up to 24 hours, 48 hours, and 72 hours. Use the Up or Down arrow to select Pump Time.

### FOR VIKING YACHTS

The Pump Mode and Time features automate the manual process of alternating the operation of Pump #1 and Pump #2 for a specific time duration (i.e., every 4 hours). ClearLine alternates seawater pumps when both centralized seawater control switches are in the "OFF" position.

**OFF** = Default position when ClearLine is operating

**AUTO** = Bypass ClearLine

**MANUAL** = Bypass ClearLine to force pumps ON

## Pump-Control Wiring

### ClearLine to Seawater Intake Pumps

The ClearLine System includes an option to make a wired connection to the vessel's centralized seawater intake pump(s) for monitoring and/or to control the process of alternating pumps for a specific duration. This optional feature is useful for vessels that have two seawater intake pumps that require scheduled manual cycling. The Pump Mode and Time features automate the manual process of alternating the operation of Pump #1 and Pump #2 for a specific time duration (i.e., every 24 hours).

**NOTE: Connection to seawater intake pumps is optional.**

1. Locate the seawater intake pump control system to be monitored and controlled. See the table below and wiring diagrams on pages 20-21 for details. Connect the Pump Cable (E) to the ClearLine Control Unit Pump Monitor and the vessel's pump controls.



**ClearLine Control Unit Cable Wiring Table - Pump Monitor and Control**

| Wire Name                    | Wire Color | Wire Description   | Pump Switch Wire Connection                         |
|------------------------------|------------|--|---|
| <b>Pump #1 Monitor</b>       | Black      | Switch #1 voltage sensing-normally open relay 1 pole 1 closure | Connect to common (center pin) for switch #1 pole 1 |
| <b>Pump #2 Monitor</b>       | Brown      | Switch #2 voltage sensing-normally open relay 2 pole 1 closure | Connect to common (center pin) of switch #2 pole 1  |
| <b>Pumps Main Relay</b>      | Orange     | Common for relay #1 and #2 pole 1                              | Connect to Auto pin of pole 1                       |
| <b>Pumps Secondary Relay</b> | Green      | Common for relay #1 and #2 pole 2                              | Connect to common (center pin) of switch #1 pole 2  |
| <b>Pump #1 On</b>            | Blue       | Switch #1 voltage sensing-normally open relay 1 pole 2 closure | Connect to common (center pin) of switch #2 pole 2  |
| <b>Pump #2 On</b>            | Violet     | Switch #2 voltage sensing-normally open relay 2 pole 2 closure | Connect to Auto pin of pole 2                       |
| <b>Pump 24 VDC</b>           | Red        | Positive DC power for switch control                           | Connect to 24 VDC positive                          |
| <b>Negative 24 VDC</b>       | Yellow     | Negative DC power for switch control                           | Connect to 24 VDC negative                          |

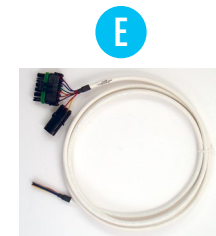

**Sample Pump Control**

## Example ClearLine Pump Control to Viking Centralized Seawater Control System Wiring Schematic

### Double Pole Switches

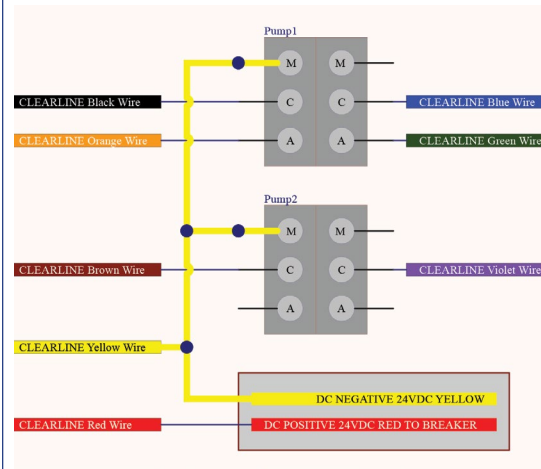

### Single Pole Switches

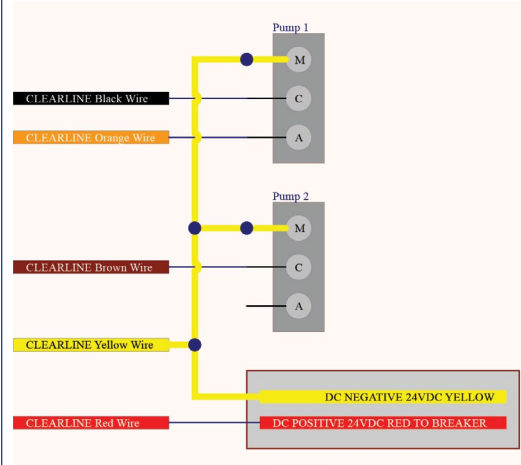

### Single Pole Switches with External VFDs

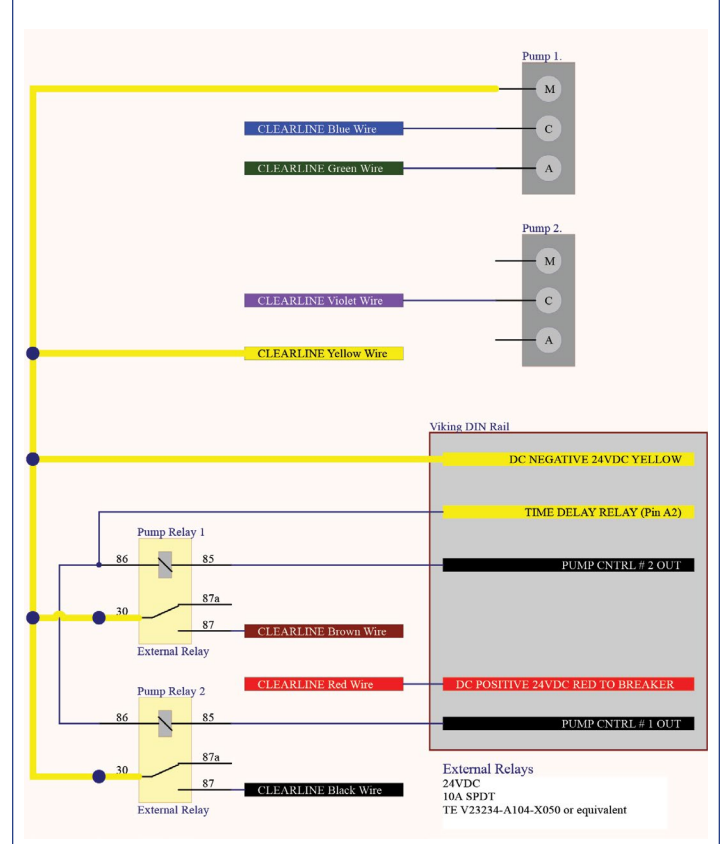

### Sample Double-Pole Wiring

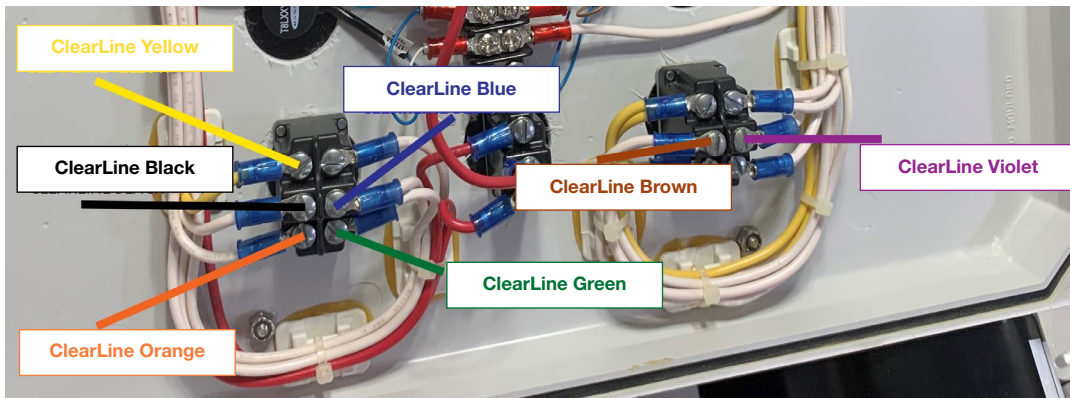

## Example ClearLine Pump Control to Viking Centralized Seawater Control System Wiring Schematic

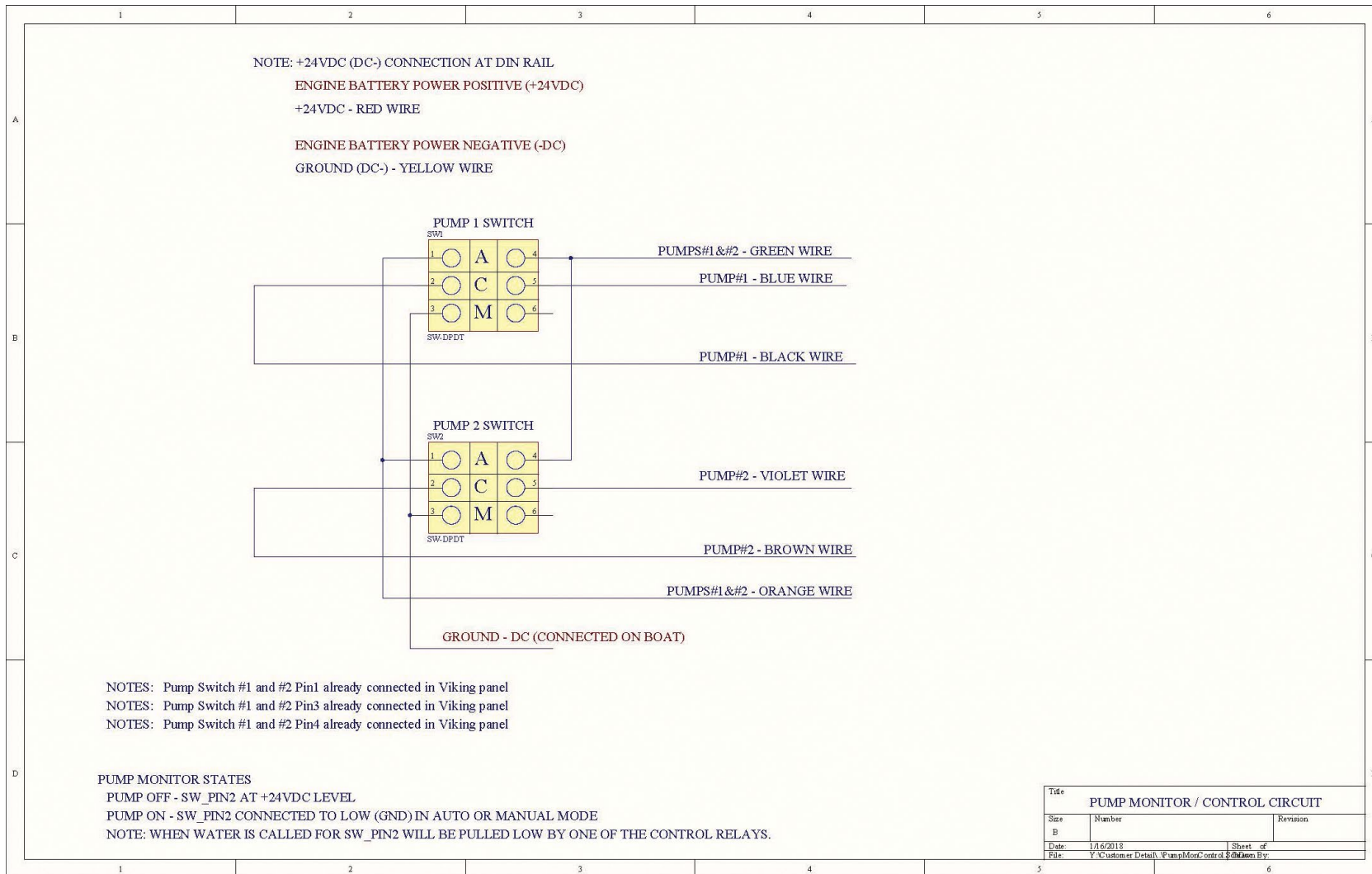

---

## Specifications

### CLEARLINE SYSTEM

---

|                               |                                  |
|-------------------------------|----------------------------------|
| <b>Power:</b>                 | 24 VDC<br>7 Amp max peak current |
| <b>Normal Operating Flow:</b> | 18-50 GPM (68-189 LPM)           |

**Maximum Pressure:** 70 psi

### CONTROL UNIT

---

**Size:** 10.0 inches (25.4 cm) - width  
7.0 inches (17.8 cm) - height (without cables)  
3.25 inches (8.3 cm) - depth

### CLEARCELL CANISTER

---

**Size:** 10.2 inches (25.6 cm) - height  
8.4 inches (21.3 cm) - diameter/width





---

**ELECTROSEA<sup>®</sup>**



(888) 384-8881  
(952) 475-8084



support@electrosea.com  
www.electrosea.com